

Engineering Aspects of Electromagnetic Shielding

Dr. Sergiu Radu

Principal Engineer, EMC Design

Sun Microsystems, Inc.

Outline

- Introduction: Electric, Magnetic and Electromagnetic shielding
- Basics approaches to shielding: field theory (Kaden) and circuit theory (Schelkunoff)
- Limits of the theoretical approaches: numerical simulations
- Practical aspects of shielding, typical requirements, grounding scheme
- Shield material: metal, plastic, typical coatings
- Shield construction: rivets, joints, seams, apertures
- Shielding and thermal issues: holes, perf patterns, honeycomb
- Shield integrity and gaskets
- Internal compartmentalization of a chassis, resonances
- Practical aspects of source - aperture coupling
- Shielding for radiated emissions, radiated immunity and ESD - reciprocity aspects and limits
- Evaluation of shielding effectiveness

Introduction

- In order to have an EMI problem we must have:
 - One or multiple noise sources (typically the CPUs, ASICs, DC/DC, other ICs, etc.)
 - One or multiple coupling paths (capacitive, inductive, galvanic, field coupling)
 - One or multiple antennas (cables, apertures, holes, seams, etc.)
- The best way is to control EMI at the source whenever possible and to add containment measures at every other level (coupling paths, antennas).
- The noise source, the coupling path and the antennas are all frequency dependent, and this increases very much the complexity of the problem.
- All the EMI problems deal with parasitics. The characterization of all the EMI aspects is never part of the data sheet, making all modeling attempts very difficult.

EMI Mechanism

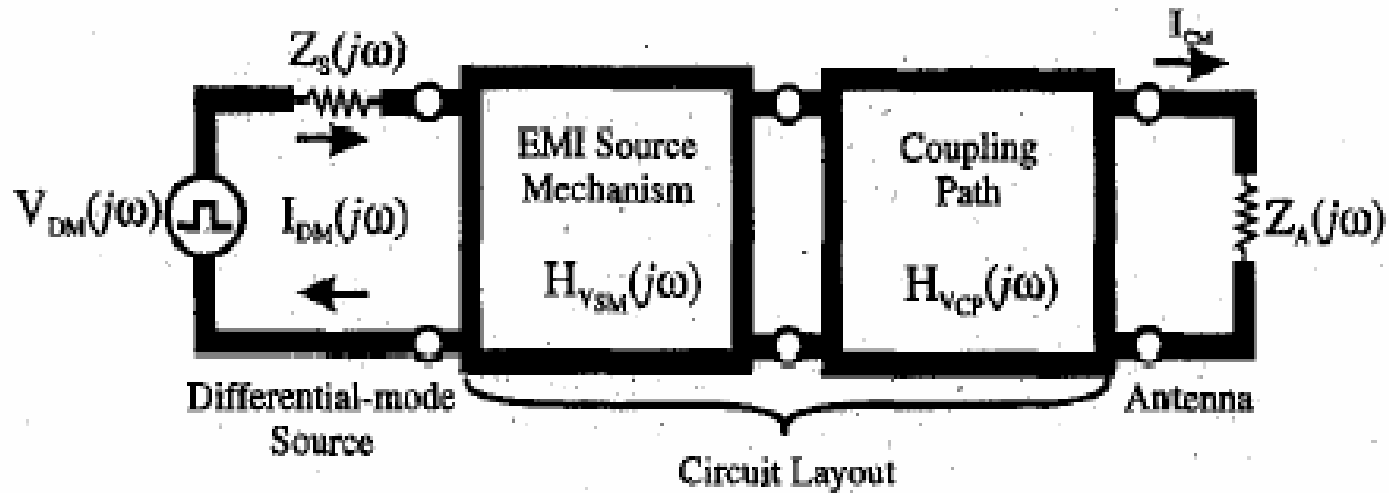

Shielding Effectiveness

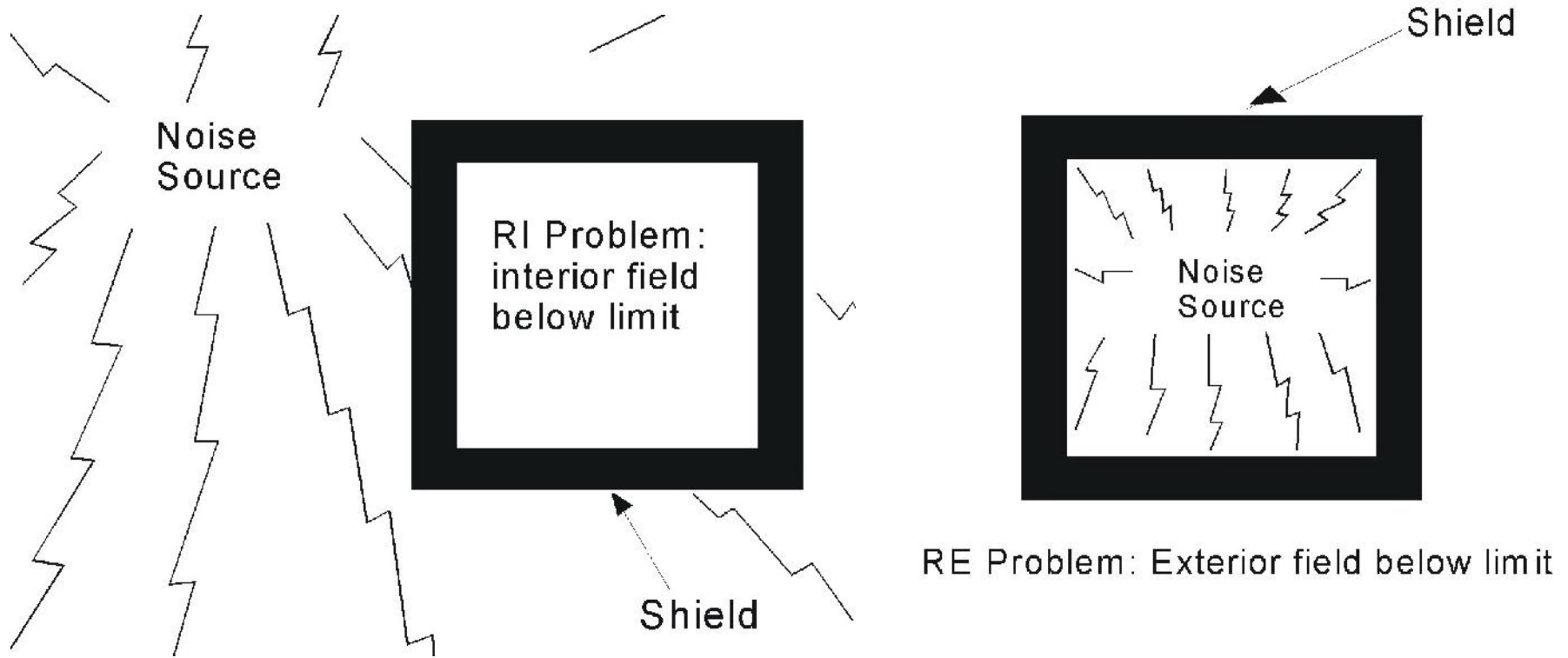

For external noise source (immunity):

$$S. E. = 20 \log \left| \frac{E_e}{E_i} \right| \quad [dB]$$

$E_e =$ Electric field (exterior)
 $E_i =$ Electric field (interior)

$$S. E. = 20 \log \left| \frac{H_e}{H_i} \right| \quad [dB]$$

$H_e =$ Magnetic field (exterior)
 $H_i =$ Magnetic field (interior)

$$S. E. = 10 \log \left| \frac{P_e}{P_i} \right| \quad [dB]$$

$P_e =$ Power (exterior)
 $P_i =$ Power (interior)

Shielding Effectiveness

Source parameters that may influence the perceived shielding:

- Source polarization
- Source – aperture distance
- Beam-pattern vs. receive antenna position
- Source impedance
- Antenna – enclosure coupling strength

Near Field vs. Far Field for Point Sources

Small electric dipole

$$(Z_W)_e = \frac{dE_\theta}{dH_\phi} = \frac{1}{\epsilon} \frac{\frac{j\omega}{v^2 r} + \frac{1}{v r^2} + \frac{1}{j\omega r^3}}{\frac{j\omega}{v r} + \frac{1}{r^2}}$$

Small current loop

$$(Z_W)_m = \frac{dE_\phi}{dH_\theta} = \mu \frac{\frac{j\omega}{r^2} - \frac{\omega^2}{v r}}{\frac{j\omega}{v r^2} + \frac{1}{r^3} - \frac{\omega^2}{v^2 r}}$$

Near Field (Reactive Field or Fresnel Zone)

$$(Z_W)_e = \frac{dE_\theta}{dH_\phi} \rightarrow \frac{1}{j\omega\epsilon r}$$

$$(Z_W)_m = \frac{dE_\phi}{dH_\theta} \rightarrow j\omega\mu r$$

Far Field (Radiation Zone, Fraunhofer Zone):

$$Z_W = \frac{dE_\theta}{dH_\phi} = \frac{1}{\epsilon v} = \frac{1}{\epsilon \frac{1}{\sqrt{\epsilon\mu}}} = \sqrt{\frac{\mu}{\epsilon}} \rightarrow \sqrt{\frac{\mu_0}{\epsilon_0}} = 120\pi = 377 \Omega$$

Near Field vs. Far Field Impedance for Point Sources

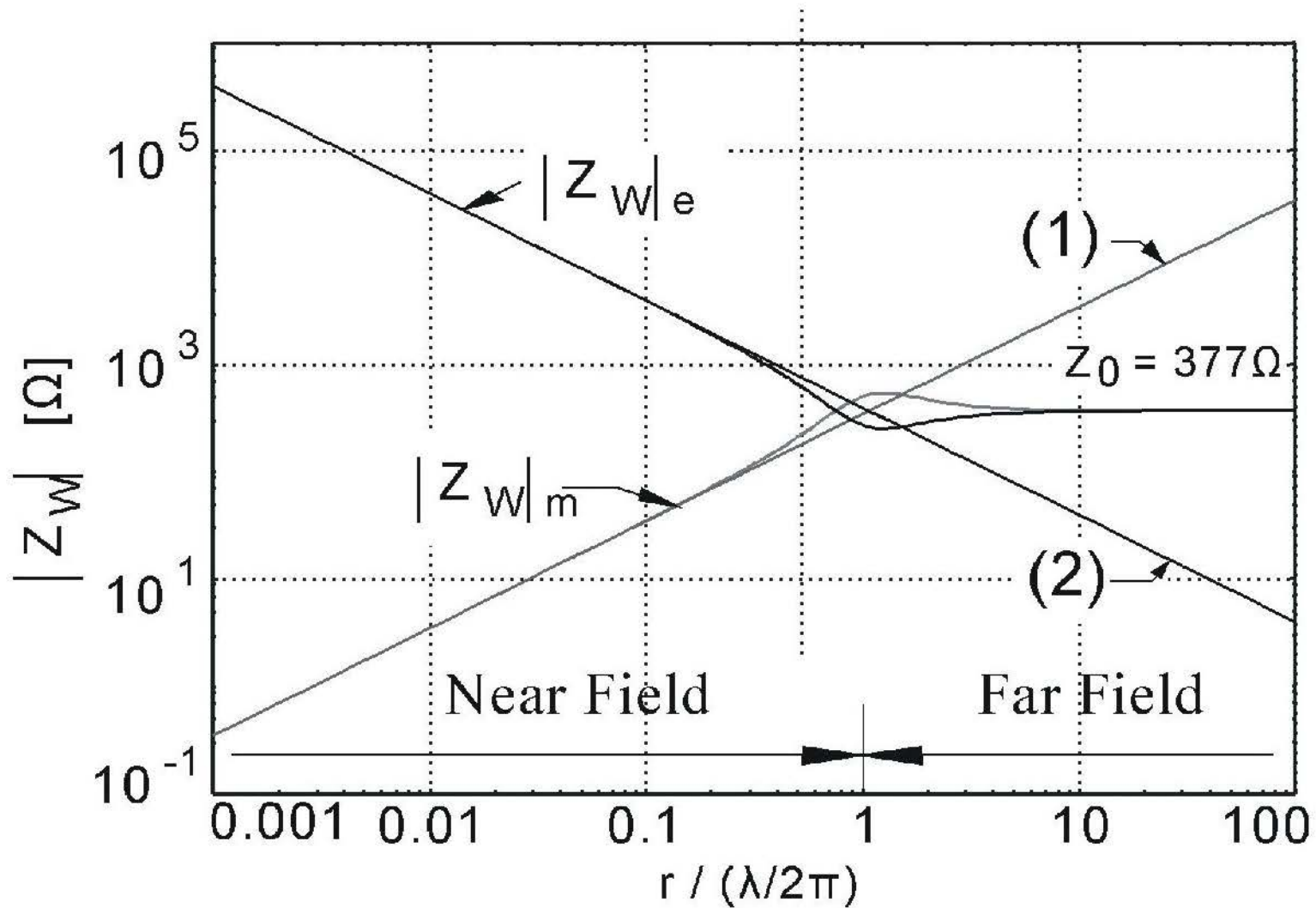

Impedance Method (TL, S.A. Schelkunoff)

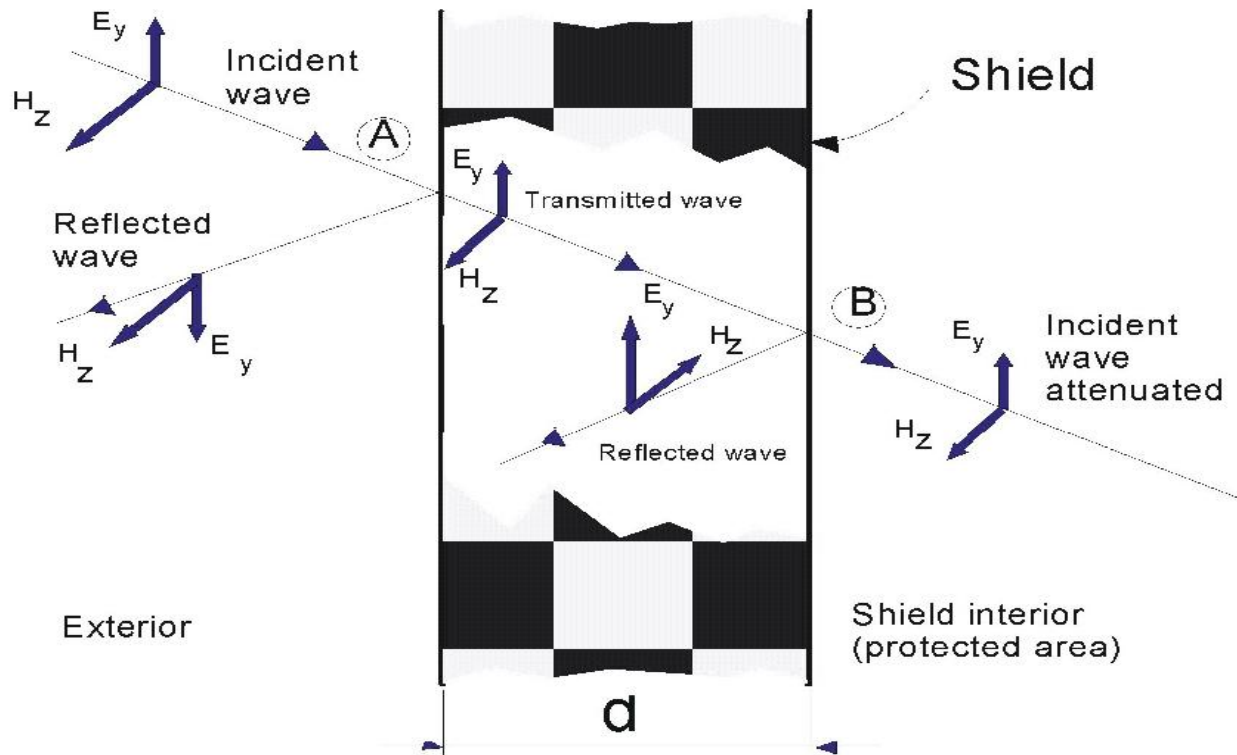

$$y = \sqrt{(R + j\omega L)(G + j\omega C)}$$

$$\Gamma = \sqrt{j\omega\mu(\sigma + j\omega\varepsilon)} \quad (\text{propagation constant})$$

$$Z_c = \sqrt{\frac{R + j\omega L}{G + j\omega C}}$$

$$Z_s = \sqrt{\frac{j\omega\mu}{\sigma + j\omega\varepsilon}} \quad (\text{medium intrinsic impedance})$$

Impedance Method – Reflected & Transmitted Waves

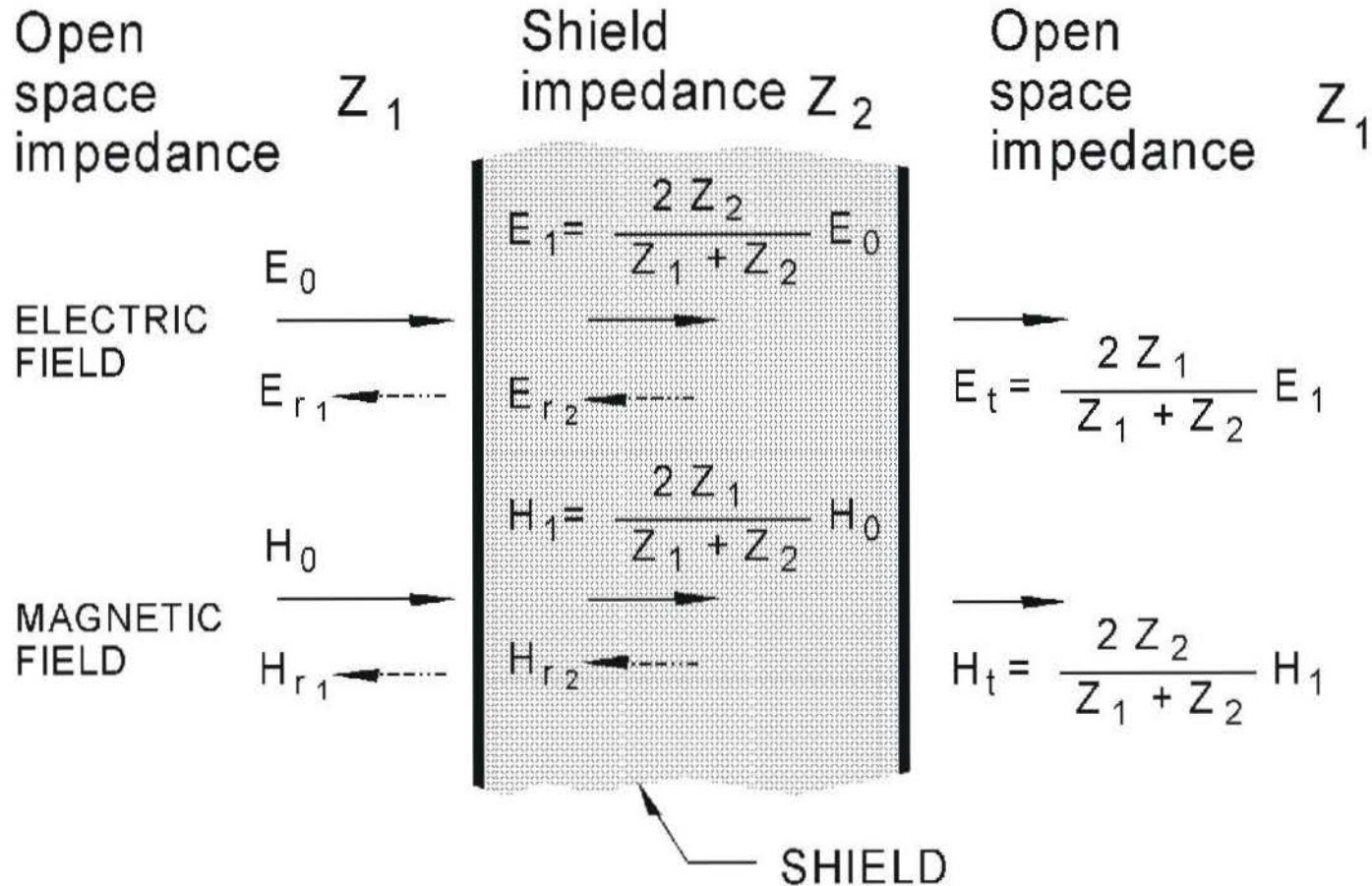

$$Z_1 = \sqrt{\frac{\mu_0}{\epsilon_0}} = 120 \pi = 377 \text{ } [\Omega]$$

(open space impedance)

$$Z_2 = \sqrt{\frac{j\omega\mu}{\sigma + j\omega\epsilon}} \text{ } [\Omega]$$

(shield intrinsic impedance)

$$R = 20 \log_{10} \left| \frac{(Z_2 + Z_1)^2}{4Z_2 Z_1} \right| \text{ } [dB]$$

(R = Reflection losses)

Absorption Losses & Skin Effect

$$\delta = \sqrt{\frac{2}{\omega \mu \sigma}} = \frac{1}{\sqrt{\pi f \mu \sigma}}$$

Where:

δ = skin depth (mm)

ω = angular (radian) frequency

μ = material permeability ($4\pi \times 10^{-7}$ H/m)

σ = material conductivity (5.82×10^7 mho/m for Cu)

f = frequency (hertz)

f	δ (copper)
60 Hz	0.0086 in (8.6 mil, 2.2 mm)
100 Hz	0.0066 in (6.6 mil, 1.7 mm)
1 kHz	0.0021 in (2.1 mil, 0.53 mm)
10 kHz	0.00066 in (0.66 mil, 0.17 mm)
100 kHz	0.00021 in (0.21 mil, 0.053 mm)
1 MHz	0.000066 in (0.066 mil, 0.017 mm)
10 MHz	0.000021 in (0.021 mil, 0.0053 mm)
100 MHz	0.0000066 in (0.0066 mil, 0.0017 mm)
1 GHz	0.0000021 in (0.0021 mil, 0.00053 mm)

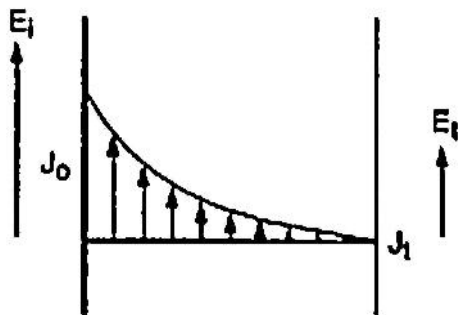

d = thickness of the shield (mm)

$$A = 8.69 \left(\frac{d}{\delta} \right) \quad [dB] \quad (\text{Absorption Losses})$$

$$B = 20 \log \left(1 - e^{-\frac{2d}{\delta}} \right) \quad [dB] \quad (\text{Correction for thin shields})$$

$$S. E. = A + R + B \quad [dB] \quad (\text{Shielding Effectiveness})$$

Magnetic Behavior of Materials

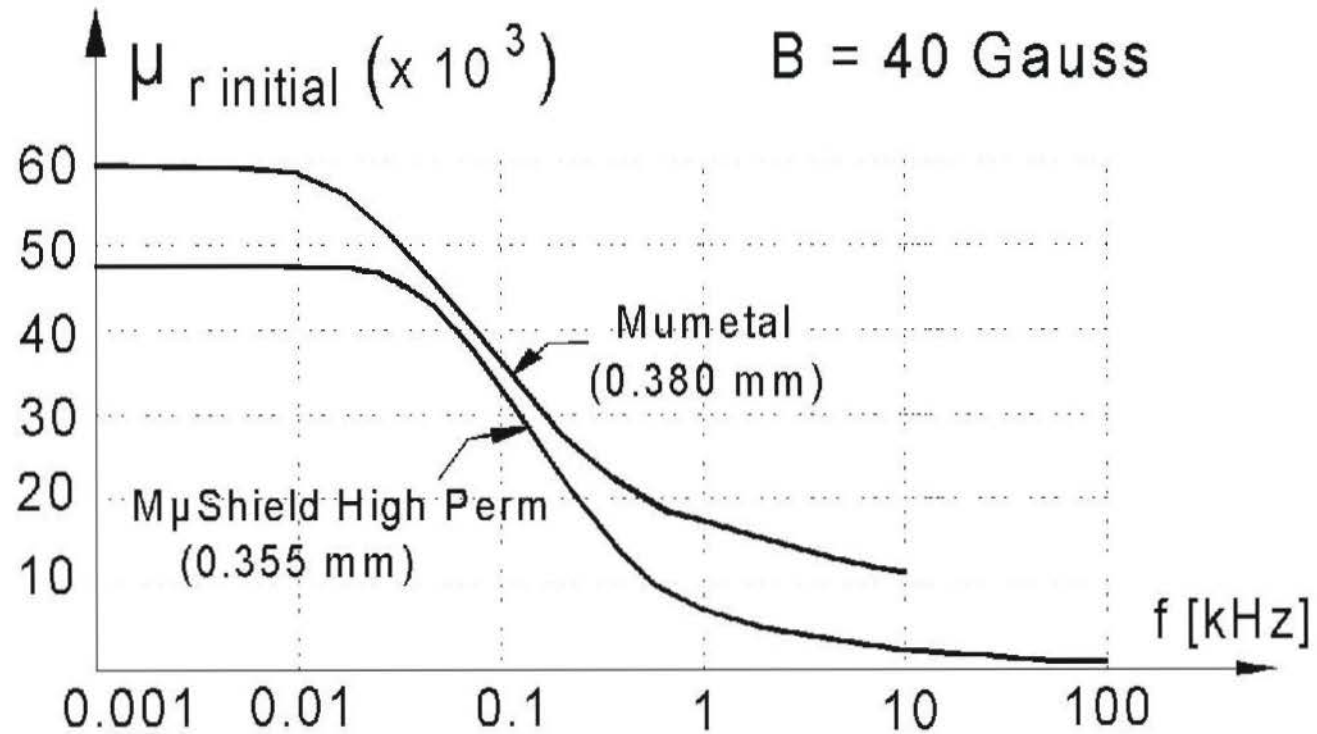

Impedance Method for Multilayer Shields

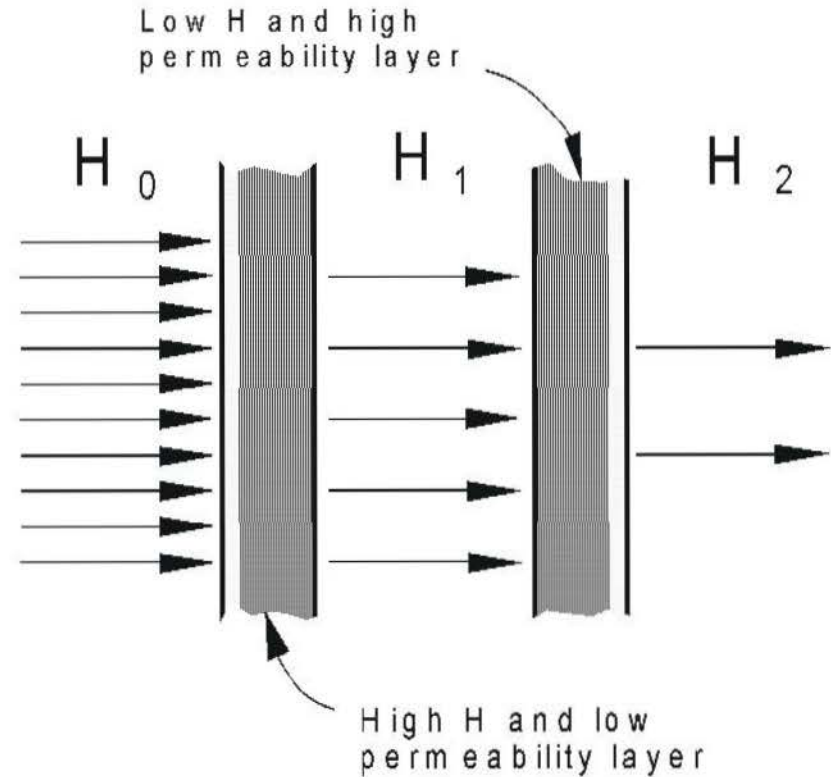
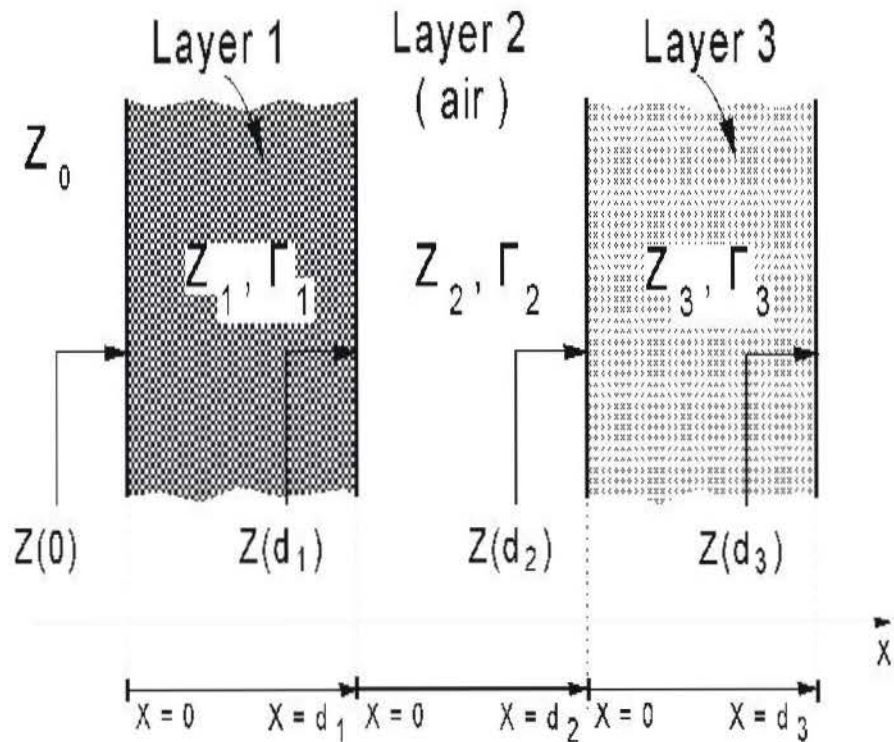

Circuit Method – H. Kaden

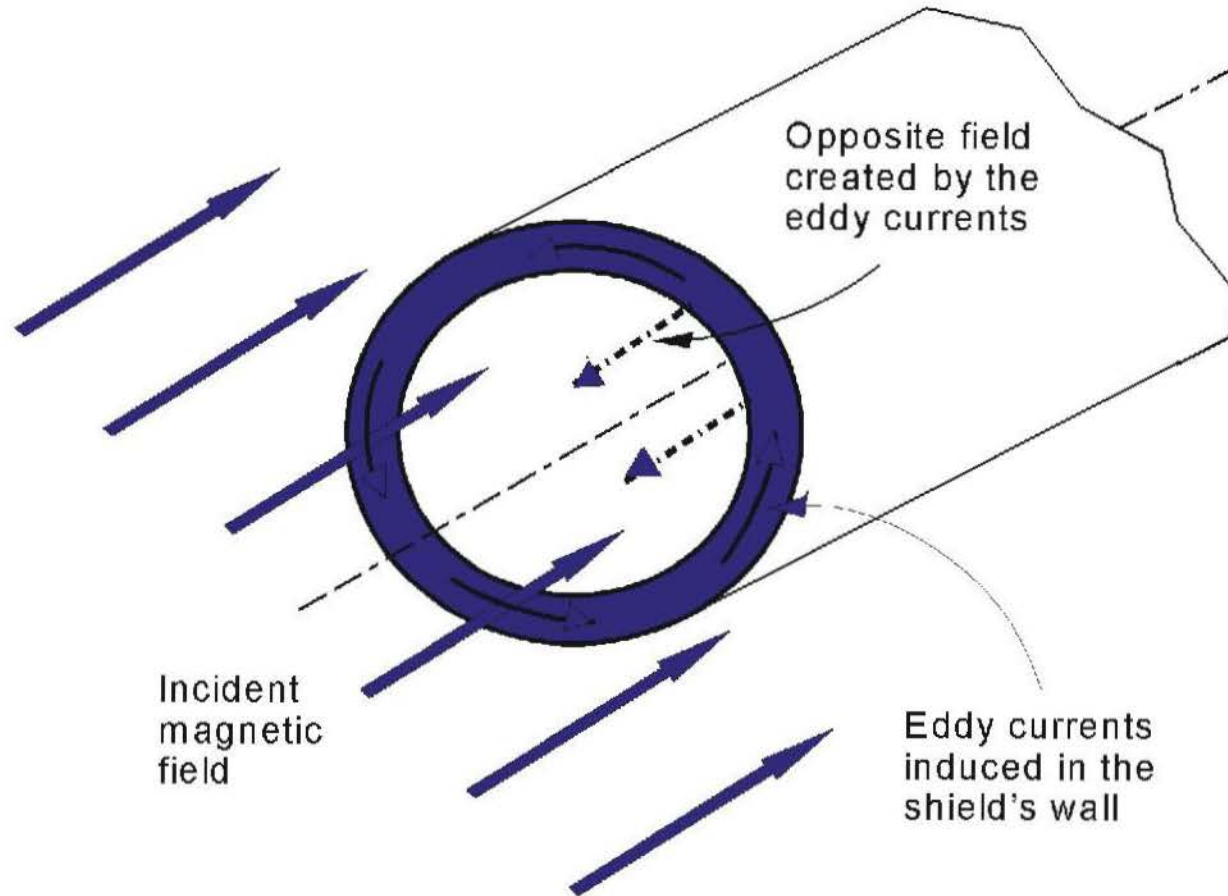

Needs continuity of the shield for the circulation of the Eddy currents (Foucault currents)

Mathematical Approach for Circuit Method

- Consider a homogeneous, isotropic, non-polarized medium without electric charges, and from Maxwell's equations obtain the Helmholtz's equations (propagation equations):

$$\Delta \bar{E} = \Gamma^2 \bar{E} \qquad \Delta \bar{H} = \Gamma^2 \bar{H} \qquad \text{(source of the field placed at infinity)}$$

- Propagation constant for harmonic field:

$$\Gamma^2 = j \omega \mu (\sigma + j \omega \epsilon)$$

- In metal:

$$\Gamma = \sqrt{j \omega \mu \sigma} = \frac{1 + j}{\delta} \quad [m^{-1}] \qquad \delta = \sqrt{\frac{2}{\omega \sigma \mu}} \quad [m]$$

- In dielectric:

$$\Gamma = j \omega \sqrt{\epsilon \mu} = j \Gamma_0 = j \frac{\omega}{v} = j \frac{2 \pi}{\lambda}$$

- Solve the Helmholtz's equation in each of the three regions: exterior space (air), interior space (air), and in the wall of the shield (metal).
- Use boundary conditions, continuity and conservation of the tangent component of the field at each of the shield's surfaces to find the integration constants and obtain the unique solution, and the S.E.
- Use the separation of variables method to solve Helmholtz's equation. This is possible only for 11 geometries with orthogonal coordinates (plan-parallel, spheric, cylindrical, elliptic, parabolic, toroidal, etc.)

Circuit Method Applied for the Plan-Parallel Shield

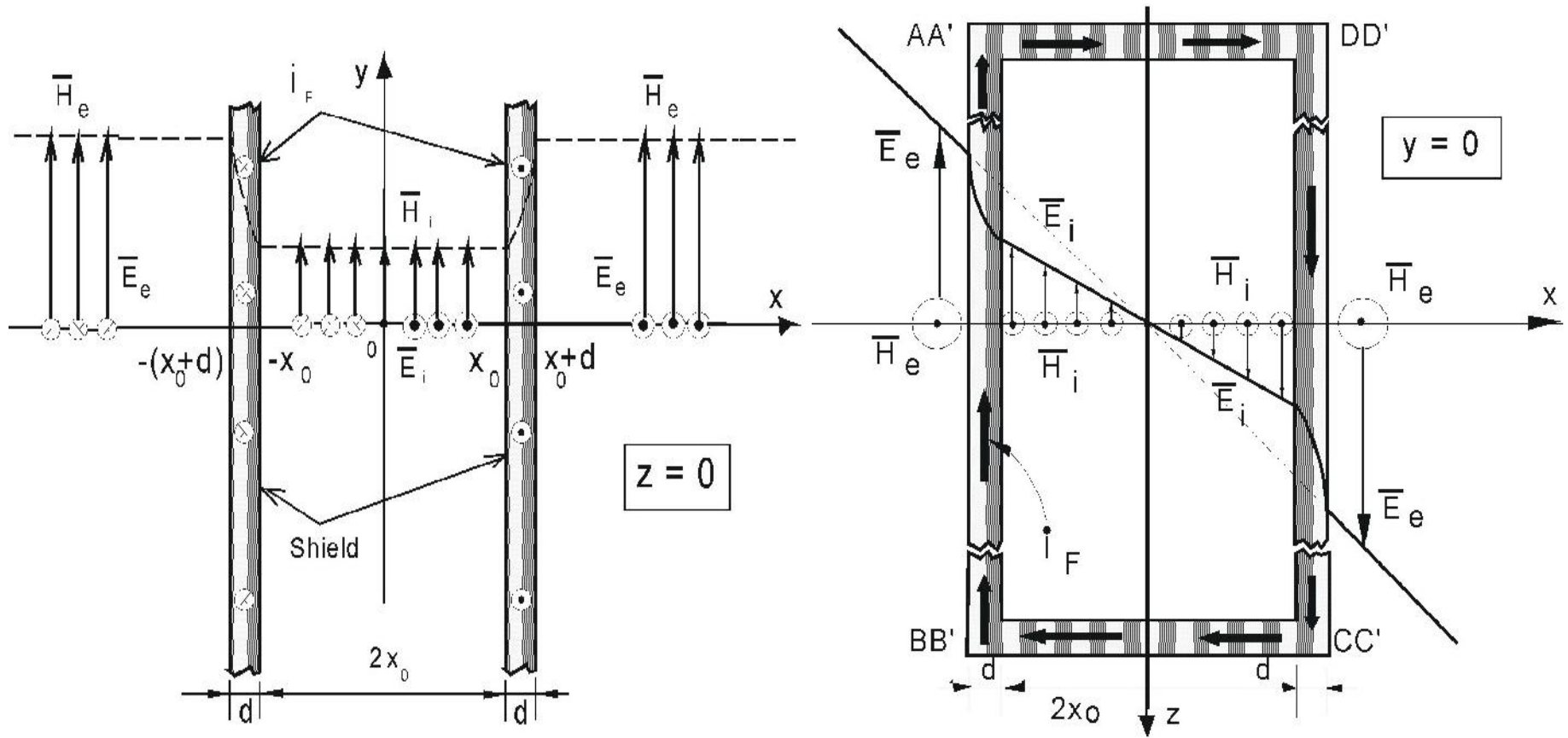

$$S.E. [dB] = 10 \log \left[\frac{1}{2} \left(\cosh \frac{2d}{\delta} + \cos \frac{2d}{\delta} \right) + \frac{\mu_0 x_0}{\mu \delta} \left(\sinh \frac{2d}{\delta} - \sin \frac{2d}{\delta} \right) + \left(\frac{\mu_0 x_0}{\mu \delta} \right)^2 \left(\cosh \frac{2d}{\delta} - \cos \frac{2d}{\delta} \right) \right]$$

Circuit Method Applied for the Spherical Shield

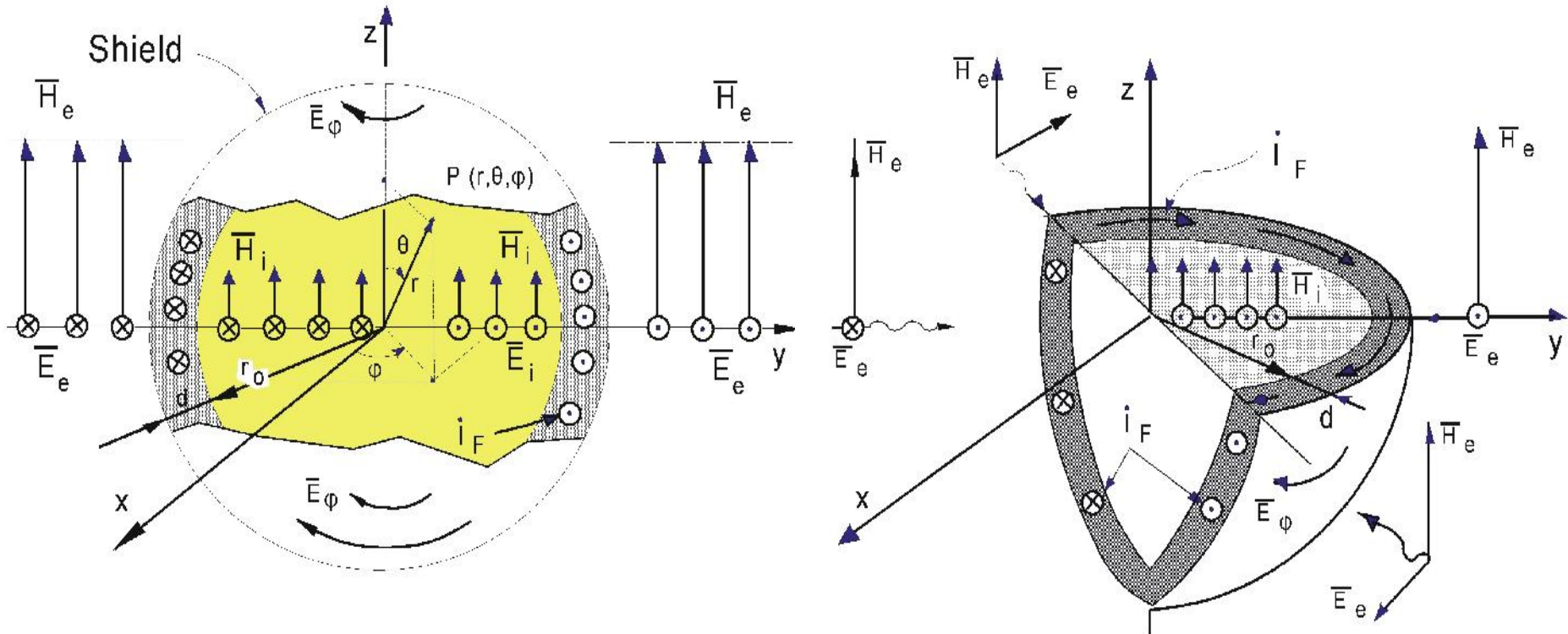

$$S.E. = 10 \log \left[\frac{1}{2} \left(\cosh \frac{2d}{\delta} + \cos \frac{2d}{\delta} \right) + (5A^2 + 2B^2 - 2AB) \frac{1}{2} \left(\cosh \frac{2d}{\delta} - \cos \frac{2d}{\delta} \right) + \dots \right]$$

$$\left[\dots + A \left(\sinh \frac{2d}{\delta} + 2 \sin \frac{2d}{\delta} \right) + B \left(\sinh \frac{2d}{\delta} - \sin \frac{2d}{\delta} \right) \right]$$

$$A = \frac{\mu \delta}{3 \mu_0 r_0} \quad B = \frac{\mu_0 r_0}{3 \mu \delta} \quad \delta = \sqrt{\frac{2}{\omega \sigma \mu}}$$

Example of Field Behavior (Spherical Shield)

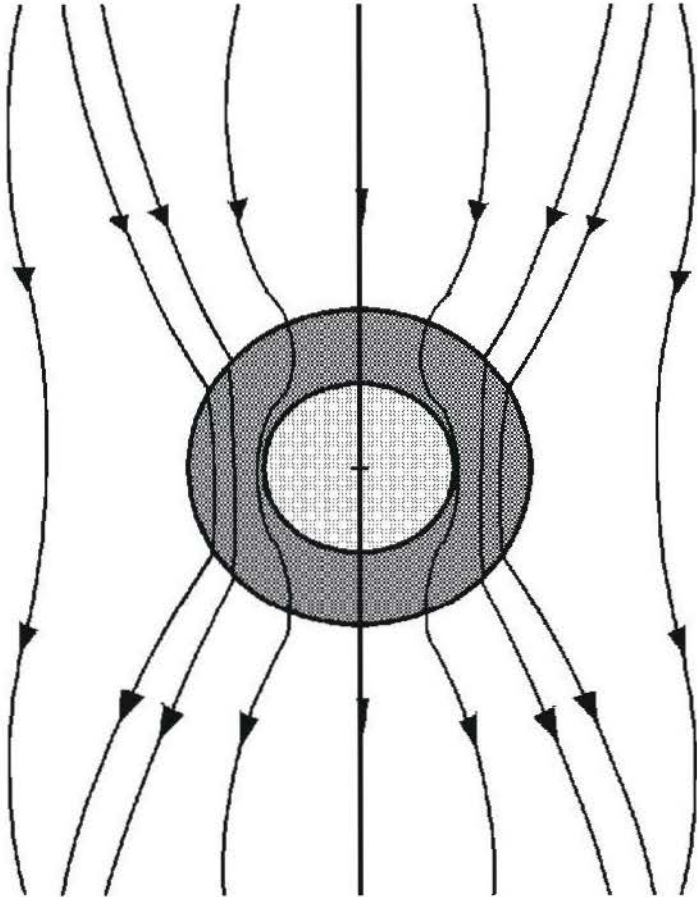

LF – Magnetic Material (no tangential field)
(No shielding effect for non-magnetic)

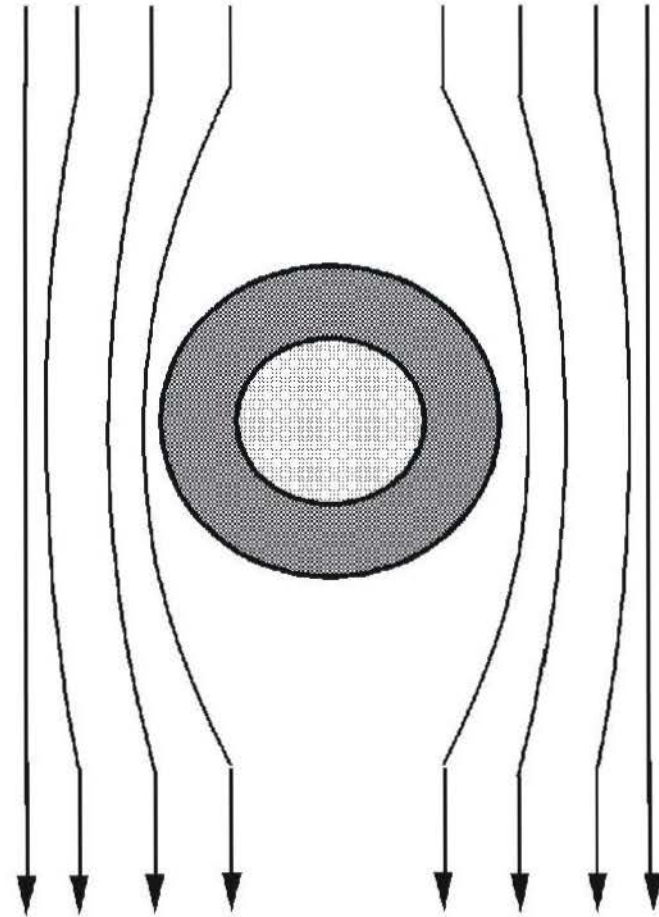

HF – Magnetic or Non-Magnetic Material
(no radial field component on the exterior) 18

Circuit Method and Multilayer Shields

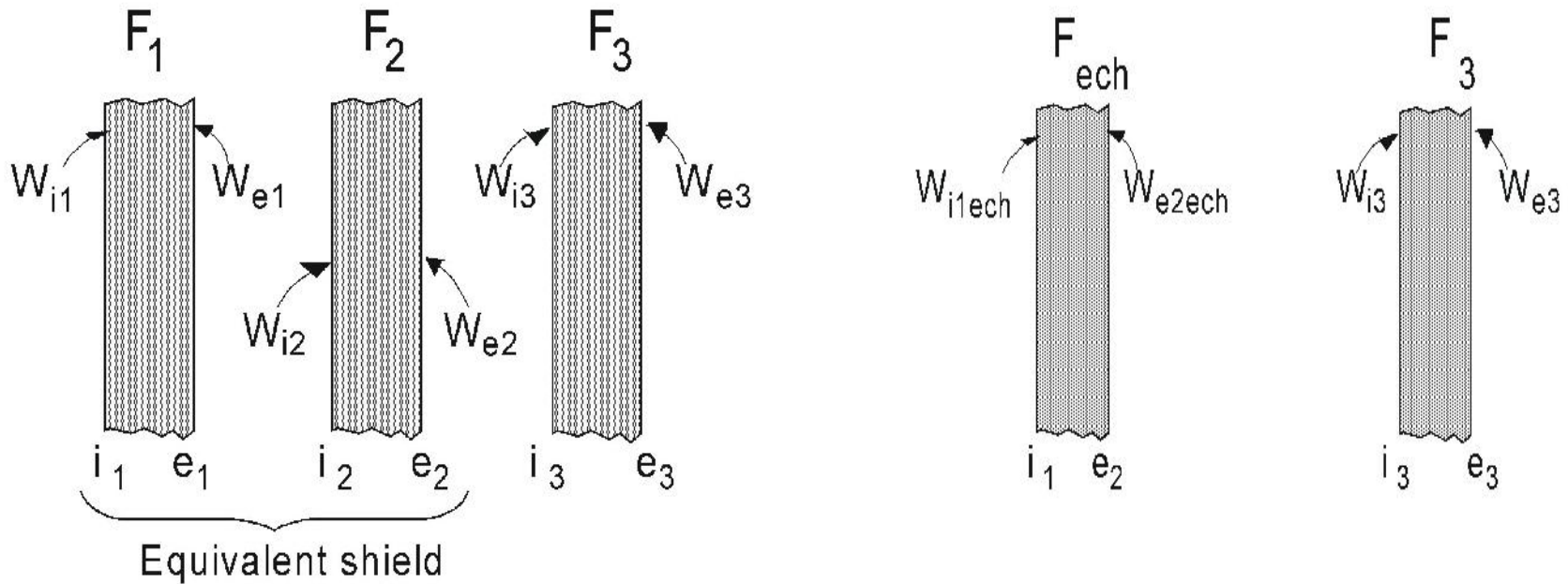

- Double shield from materials with the same magnetic behavior (Cu + Al) is worse than a single shield with equivalent thickness. If the materials have different magnetic behavior the double shield is with 6dB better (for example Cu+ Ni). In general, equal thickness is best.
- Triple shield works best with materials of equal thickness and alternating magnetic behavior, the most conductive toward the noise source.
- There is a difference between laminated shields and double shields (air separation).

Limits of the Analytical Methods

- Analytical methods:
 - impedance method (Schelkunoff) - infinite sheet of metal
 - separation of variables (Kaden) – theoretically possible for 11 geometries)
- Physical insight and precision - perfect as a benchmark for the evaluation of the numerical methods.
- Numerical simulation (FDTD, FEM, MoM, etc.) - can't be used for real life situations, no physical insight, difficult to characterize the noise source, internal reflections, large size of the file, etc.
- Very good for simple cases to analyze a trend or principle.
- Experimental methods - the only real validation of the analytical or numerical models.
- In the end, all these are about material and thickness of the shield, and to a little extent about the geometry (circuit method).

Shielding and Reciprocity

- Reciprocity principle is applicable only to passive and linear circuits (a CPU, ASIC, IC is active and non-linear).
- Reciprocity requires us to consider only those parts of the system that meet the criteria of “passiveness” and “linearity”. In this sense, within an electronic system, the properties of radiators/sensors can often be assumed to be reciprocal, just as is the case with antennas.
- In shielding practice, we can find non-linear effects, like the "rusty bolt" effect, which results in nonlinear and non-reversible conductivity (diode). Another typical example from shielding practice, is a multilayer shield, with one of the layers having nonlinear magnetic permeability.
- If the shield is linear, the reciprocity principle requires that $Z_{21} = Z_{12}$. The same requirements for passive, linear, circuits hold. As long as the shield is a passive network and its material exhibits linear electric and magnetic properties, the reciprocity theorem holds, and the same shielding parameters are true for emissions and susceptibility. However, this is true only at the levels of the **shield transfer function**, but not at the **system** level shielding effectiveness.
- For example, a dominant radiator in the system (emissions case) was not necessarily the dominant victim in the same system (immunity case). For instance, one of the reasons that the radiator is dominant for emissions may be a high level of signal within it which, on the other hand, makes this particular part of the system more immune to EMI. Typically, the Tx (transmitting) output signal is 20dB stronger than Rx (receiving) input signal.

Evaluation of Shielding Materials (MIL285, IEEE 299, ASTM D4935)

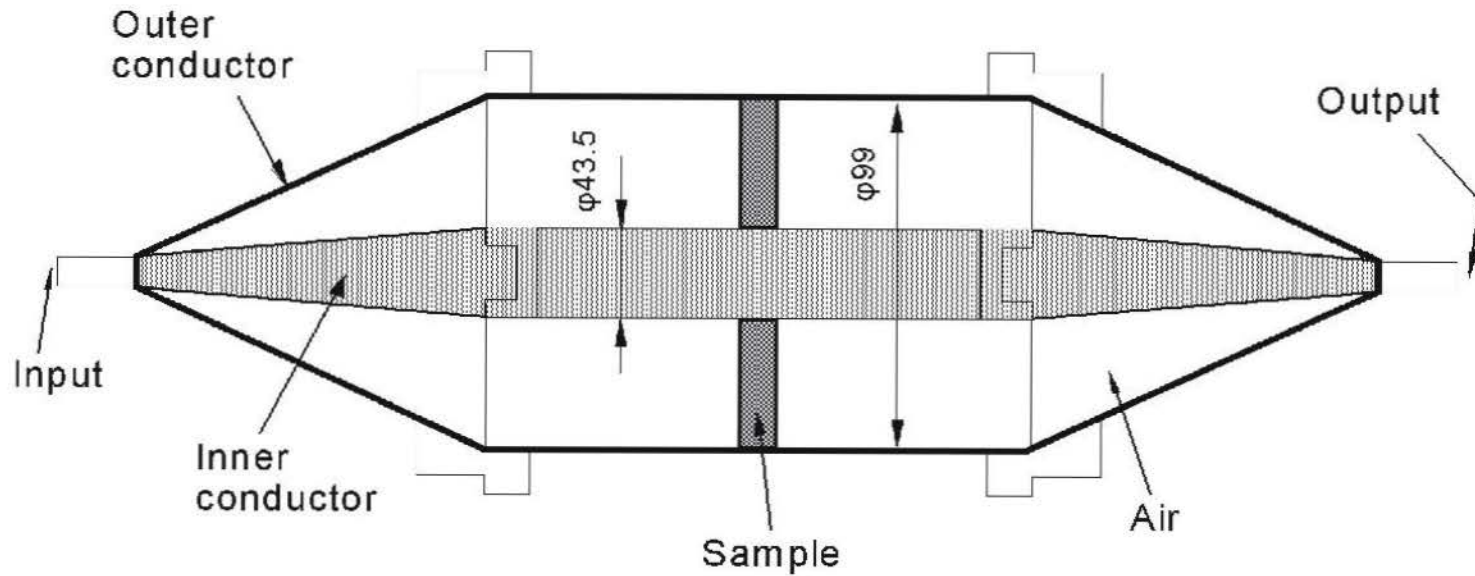
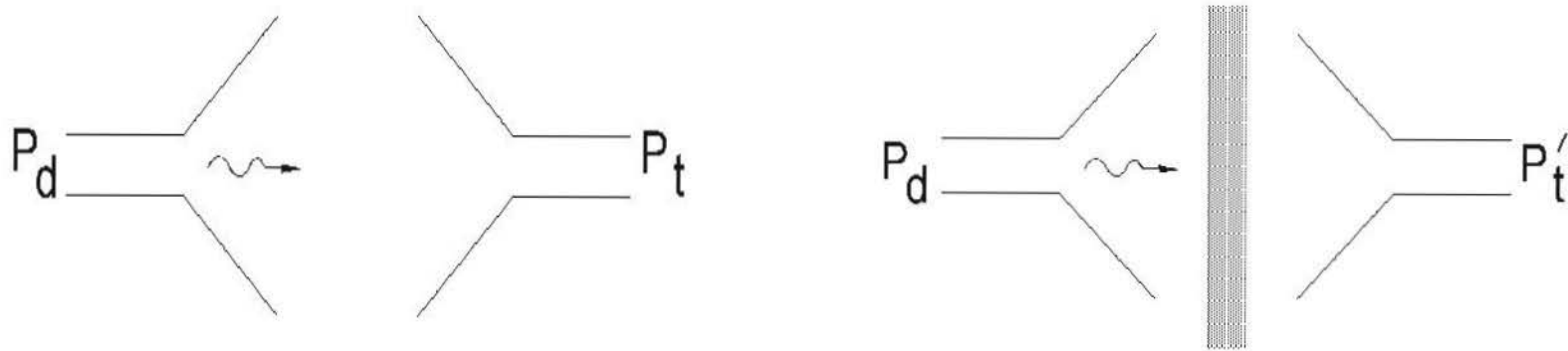

Evaluation of Shielding Materials

Dual TEM Cell*

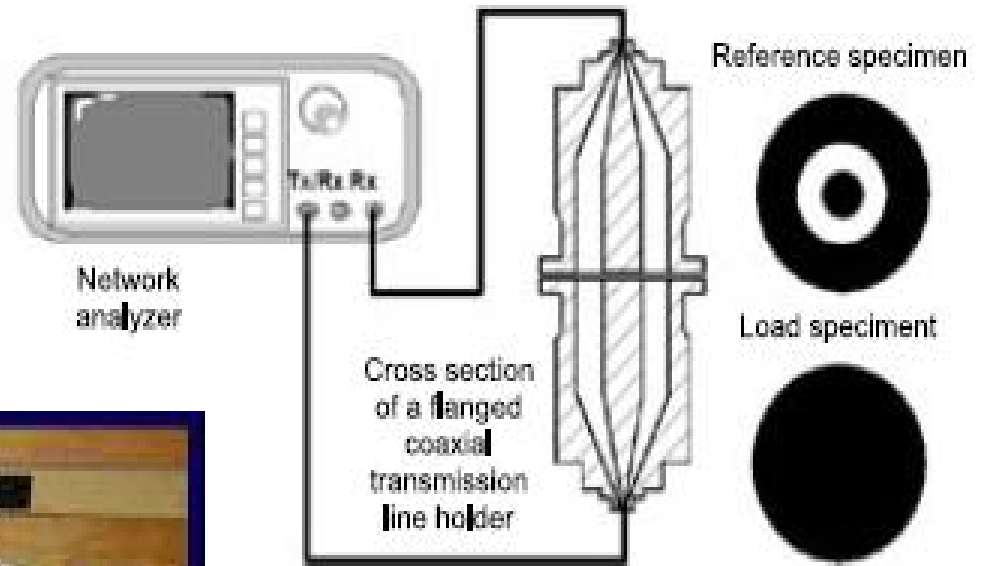

ASTM D4935 Coaxial TEM

* Two coupled stirred mode reverberation chambers as a HF alternative (Qinetiq)

IEEE 299 – Measuring SE of Enclosures

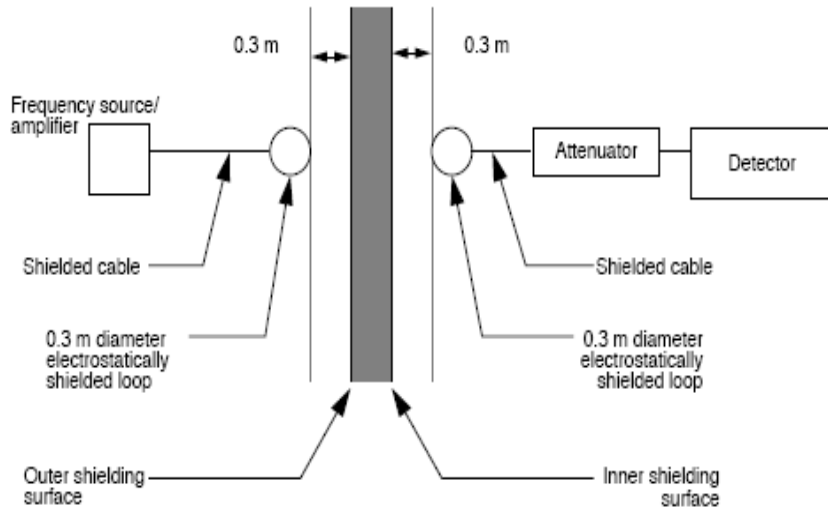

Schematic diagram of the test configuration for magnetic tests showing dimensions of transmit (TX) and receive (RX) antennas

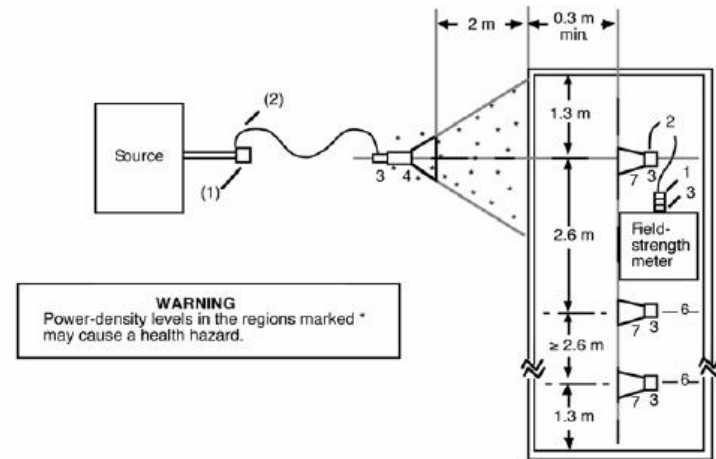

a) Broad-area microwave penetration

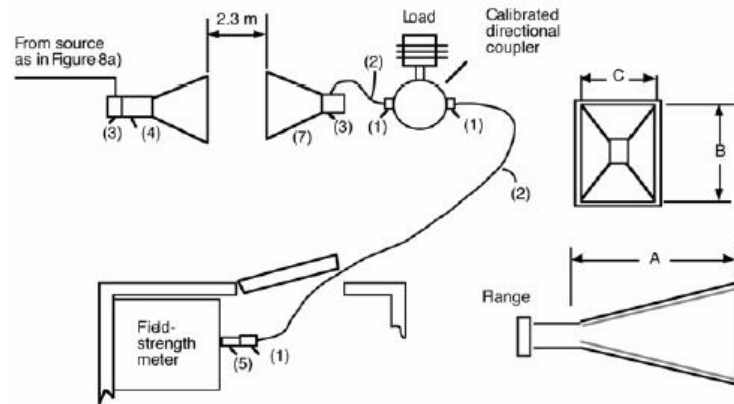

b) Enclosure free-field simulation

c) Standard gain horn dimensions

NOTES

- 1—Type N adapter coax to waveguide (if needed).
- 2—Coaxial cable or waveguide.
- 3—Adapter (if needed).
- 4—Transmitter antenna, Table 4, or ridged horn.
- 5—Attenuator (if not within field-strength meter).
- 6—Additional centerlines so that all areas are illuminated.
- 7—Receiving horn antenna, Figure 8c) and Table 4; dimensions relate to standard EIA waveguides, flanges, and waveguide-to-coaxial transitions.

Experimental Setup

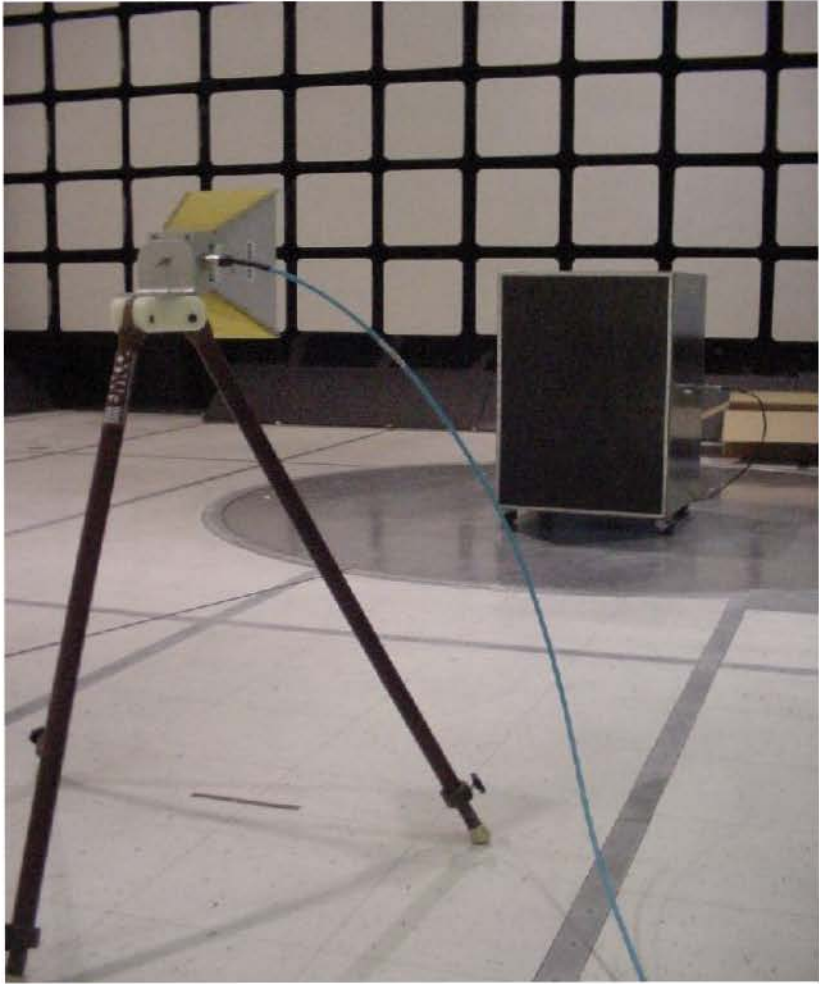

Chassis Resonances

The resonance frequencies in a rectangular box are given by:

$$f_{ijk} = \frac{c}{2 \pi \sqrt{\mu_r \epsilon_r}} \sqrt{\left(\frac{i \pi}{L}\right)^2 + \left(\frac{j \pi}{H}\right)^2 + \left(\frac{k \pi}{W}\right)^2}$$

$$f_{ijk} = 150 \sqrt{\left(\frac{i}{L}\right)^2 + \left(\frac{j}{H}\right)^2 + \left(\frac{k}{W}\right)^2} \quad (\text{ for vacuum })$$

L = length

H = height

W = width

where the case $i=j=k=0$ is forbidden

Rectangular Box - Lowest Resonance Frequencies

$$f_0 = \begin{bmatrix} 0 & 8.605 \cdot 10^8 & 1.721 \cdot 10^9 & 2.581 \cdot 10^9 \\ 3.368 \cdot 10^8 & 9.241 \cdot 10^8 & 1.754 \cdot 10^9 & 2.603 \cdot 10^9 \\ 6.737 \cdot 10^8 & 1.093 \cdot 10^9 & 1.848 \cdot 10^9 & 2.668 \cdot 10^9 \\ 1.011 \cdot 10^9 & 1.327 \cdot 10^9 & 1.996 \cdot 10^9 & 2.772 \cdot 10^9 \end{bmatrix}$$

$$f_2 = \begin{bmatrix} 4.463 \cdot 10^8 & 9.693 \cdot 10^8 & 1.778 \cdot 10^9 & 2.62 \cdot 10^9 \\ 5.591 \cdot 10^8 & 1.026 \cdot 10^9 & 1.81 \cdot 10^9 & 2.641 \cdot 10^9 \\ 8.081 \cdot 10^8 & 1.18 \cdot 10^9 & 1.901 \cdot 10^9 & 2.705 \cdot 10^9 \\ 1.105 \cdot 10^9 & 1.4 \cdot 10^9 & 2.045 \cdot 10^9 & 2.808 \cdot 10^9 \end{bmatrix}$$

$$f_1 = \begin{bmatrix} 2.231 \cdot 10^8 & 8.889 \cdot 10^8 & 1.735 \cdot 10^9 & 2.591 \cdot 10^9 \\ 4.041 \cdot 10^8 & 9.506 \cdot 10^8 & 1.768 \cdot 10^9 & 2.613 \cdot 10^9 \\ 7.097 \cdot 10^8 & 1.115 \cdot 10^9 & 1.862 \cdot 10^9 & 2.677 \cdot 10^9 \\ 1.035 \cdot 10^9 & 1.346 \cdot 10^9 & 2.008 \cdot 10^9 & 2.781 \cdot 10^9 \end{bmatrix}$$

$$f_3 = \begin{bmatrix} 6.694 \cdot 10^8 & 1.09 \cdot 10^9 & 1.847 \cdot 10^9 & 2.667 \cdot 10^9 \\ 7.494 \cdot 10^8 & 1.141 \cdot 10^9 & 1.877 \cdot 10^9 & 2.688 \cdot 10^9 \\ 9.497 \cdot 10^8 & 1.282 \cdot 10^9 & 1.966 \cdot 10^9 & 2.751 \cdot 10^9 \\ 1.212 \cdot 10^9 & 1.487 \cdot 10^9 & 2.105 \cdot 10^9 & 2.852 \cdot 10^9 \end{bmatrix}$$

- At higher frequency (for example >1GHz), the enclosure supports a very large number of modes. Lowest modes: 223, 336, 404, 446, 559, 669, 673, ... MHz.
- An empty box has very high Q, very sharp resonances. The energy stored is proportional to volume, and losses are proportional with the surface area.

Field Distributions at Resonant Frequencies

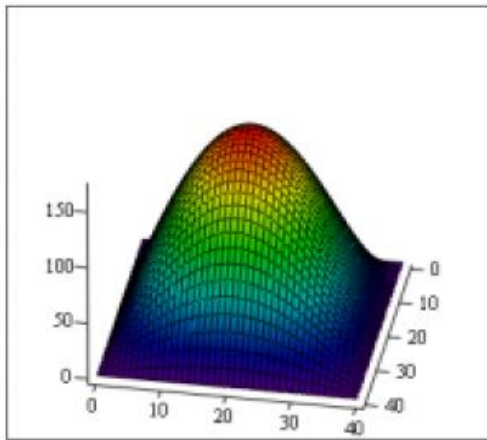

EyXZ

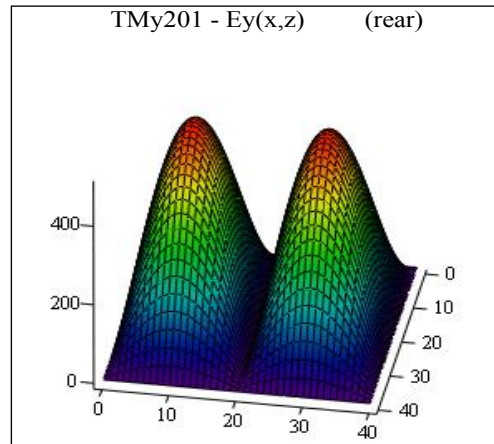

EyXZ

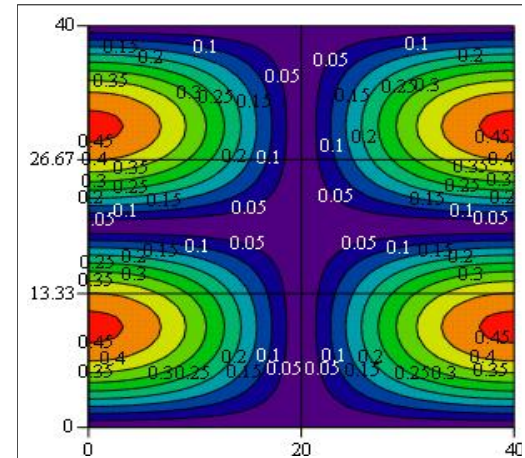

HxXZ

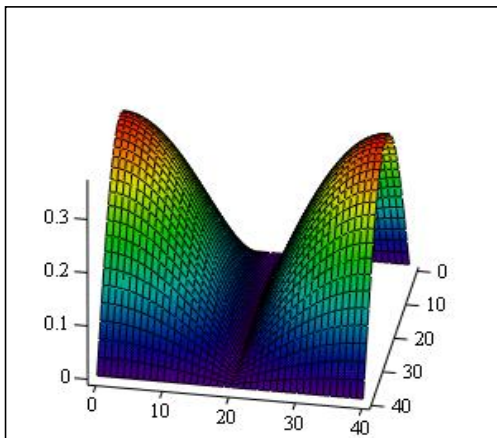

HzXZ

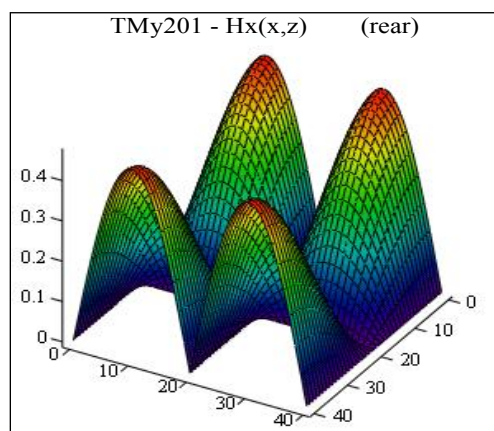

HxXZ

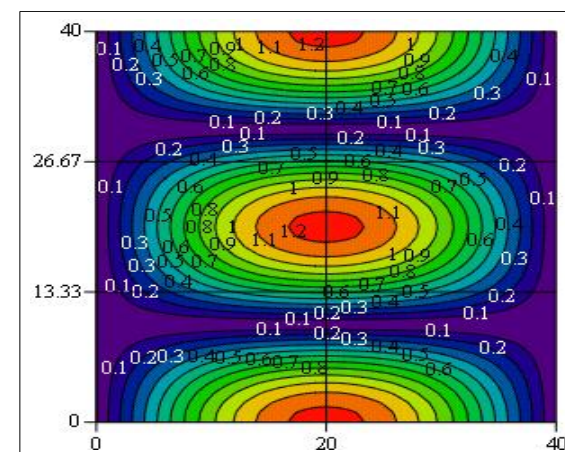

HzXZ

- Empty box: $Q=5000$, Fully loaded, densely populated box: $Q=5-25$ (practical implications)
- Use extensively internal compartmentalization (limit excitations, lower Q , upper f)

Significance of modes

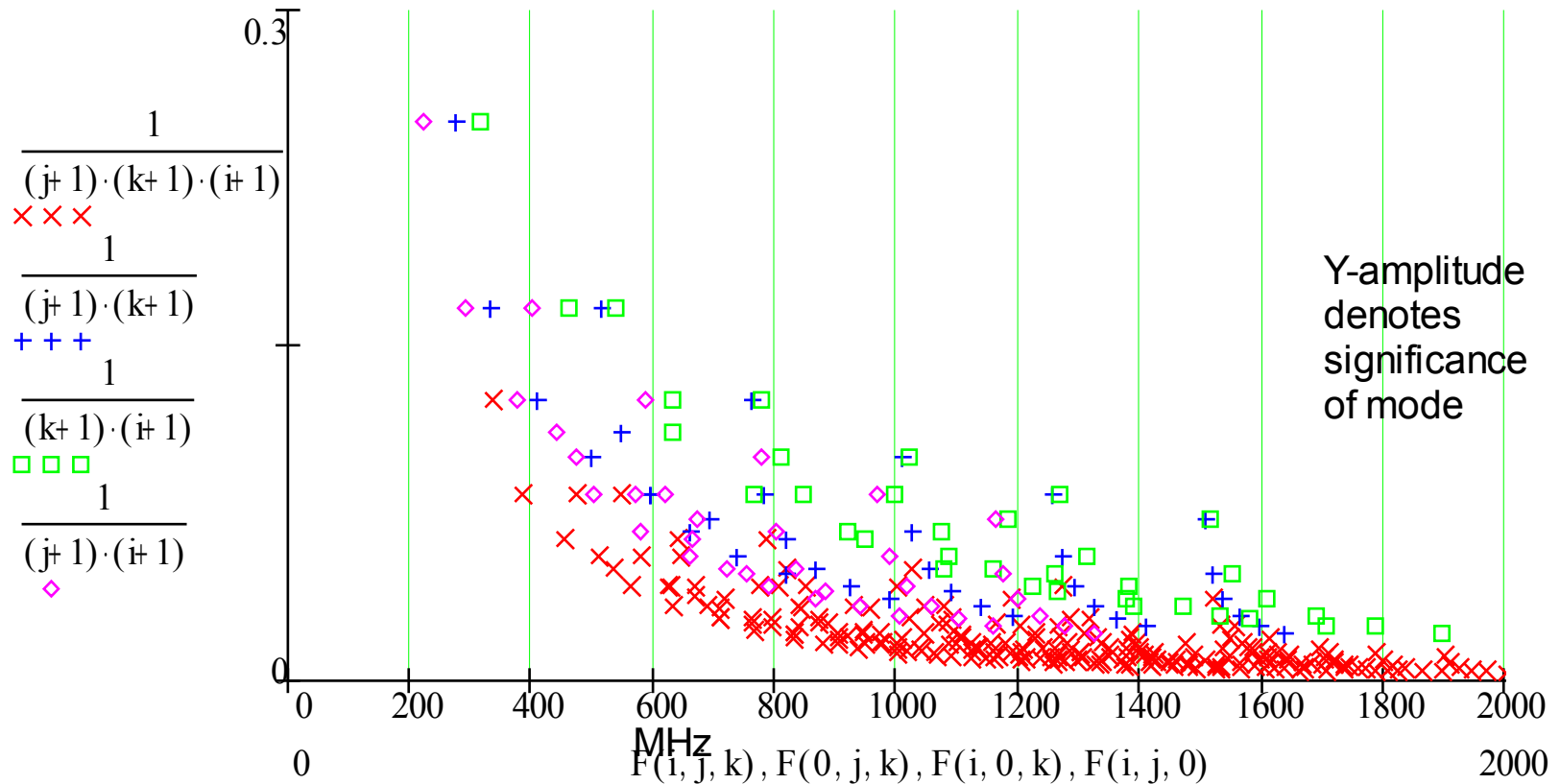

- Most energy stored in the lower modes – Can we limit the upper frequency of interest?
Yes, use 3GHz as a practical upper limit for the internal resonances (Exceptions)

Far Field Estimations using Analytical Methods

- Based on measuring Q of the enclosure
- Based on the measurement of the field in the aperture and the Huygens principle
- Based on the evaluation of the field in the aperture and Bethe's theory of diffraction through small holes
- Problems: multiple sources without accurate characterization, multiple coupling paths, and multiple apertures - the real field in the aperture can't be correctly estimated in early phases of the design.
- The main results: trends and possible estimation of the relative effect of a modification.

Why Apertures Radiate?

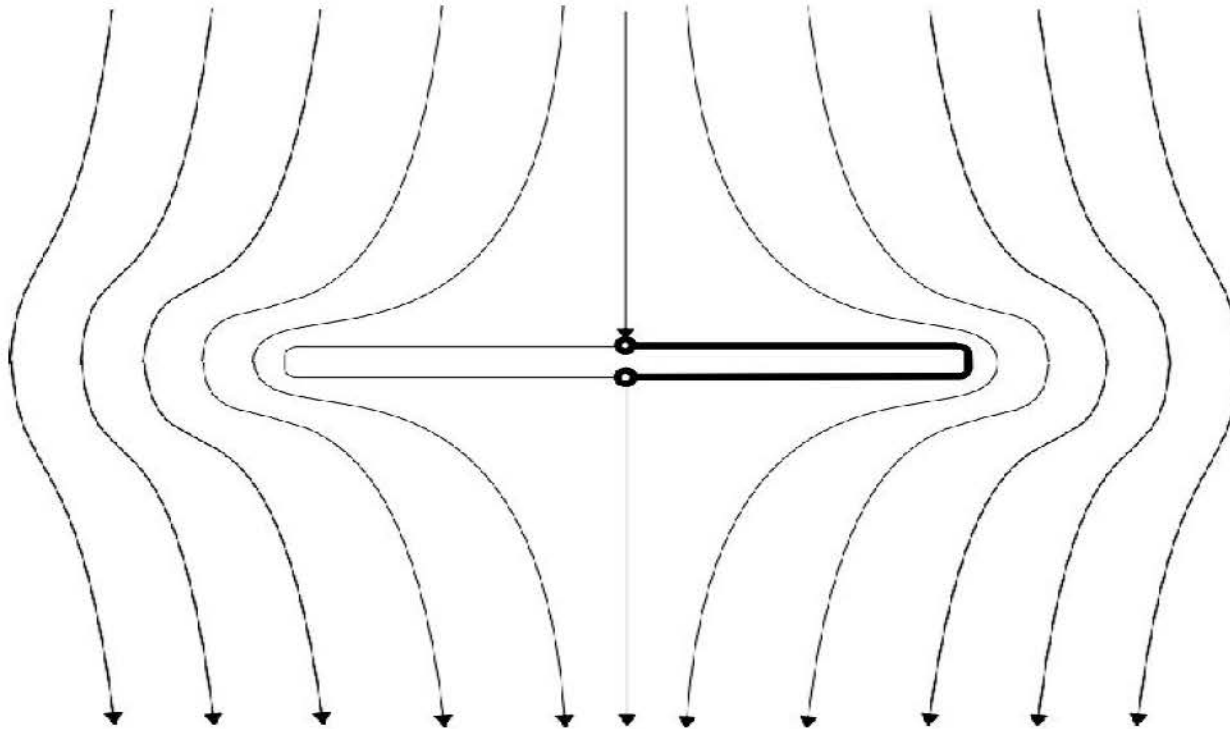

SLOT CONTAINS RESISTANCE & INDUCTANCE

$$Z = R + j X_L$$

$$V = I Z$$

$$E\text{-field} \sim V$$

Why joints radiate?

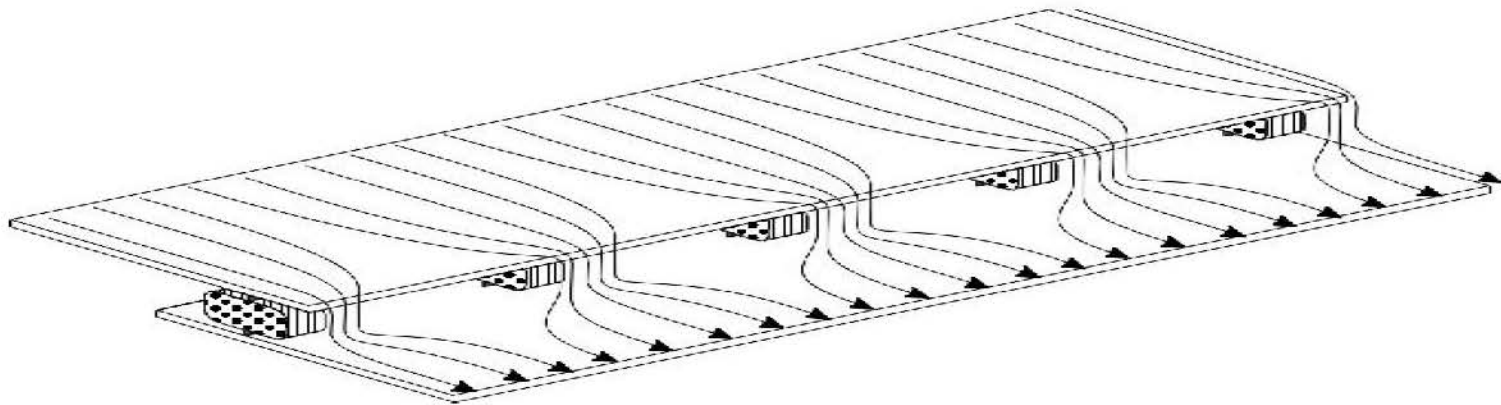
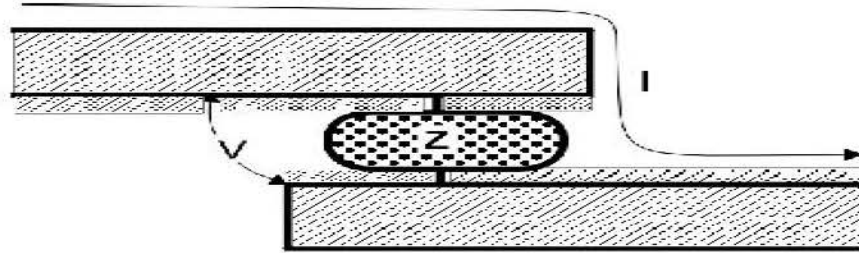

- Similar behavior for screws & rivets

Slot and Aperture Radiation

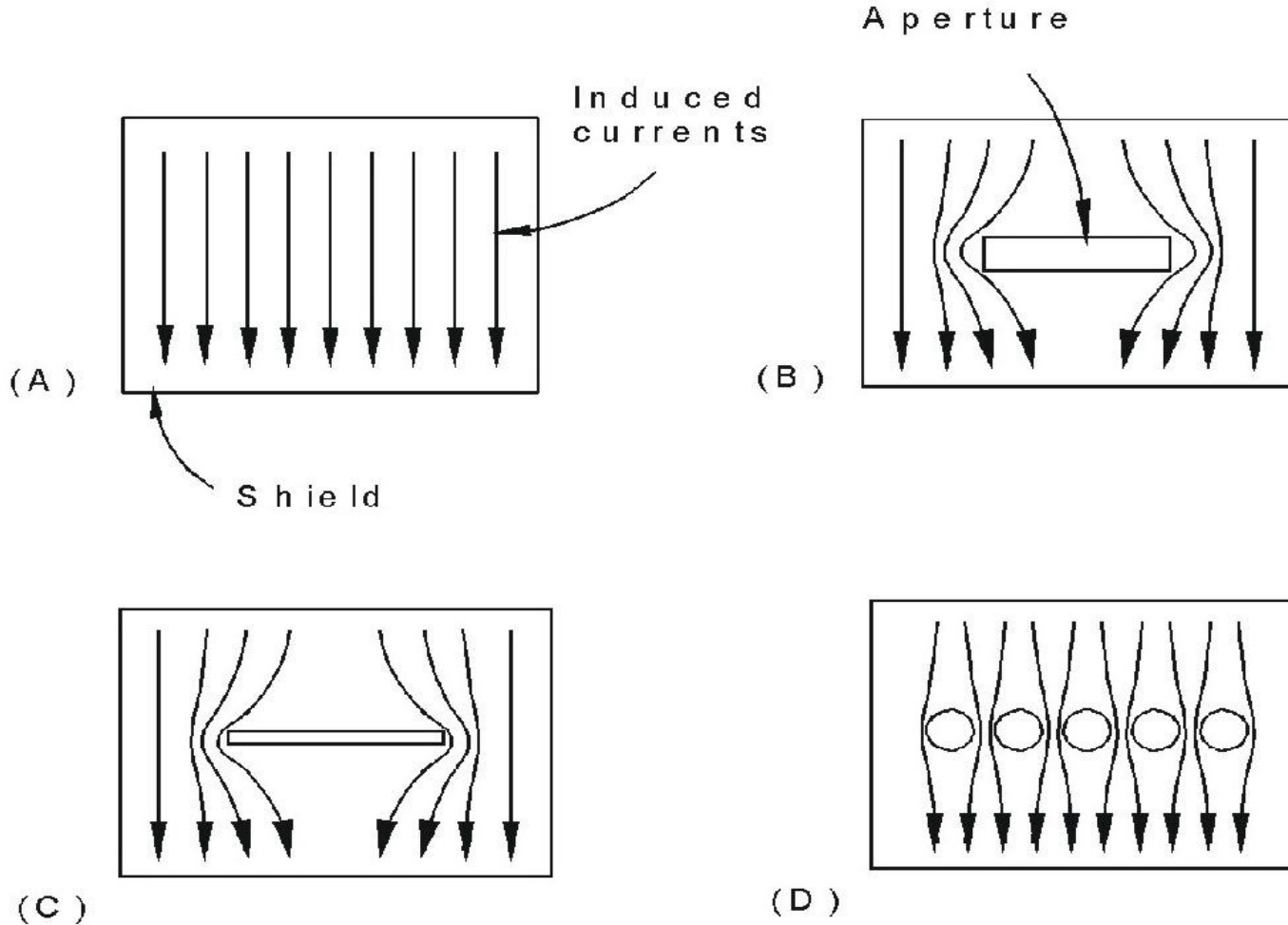

$$S.E. = 20 \log \left(\frac{\lambda}{2L} \right)$$

$$S.E. = -10 \log (n)$$

- A slot behaves like an equivalent dipole with orthogonal polarization (Babinet). For example, at 1GHz, a slot of 0.6" length or less will still provide a S.E.=20dB

Slot Shape and Shielding Effectiveness (TLM)

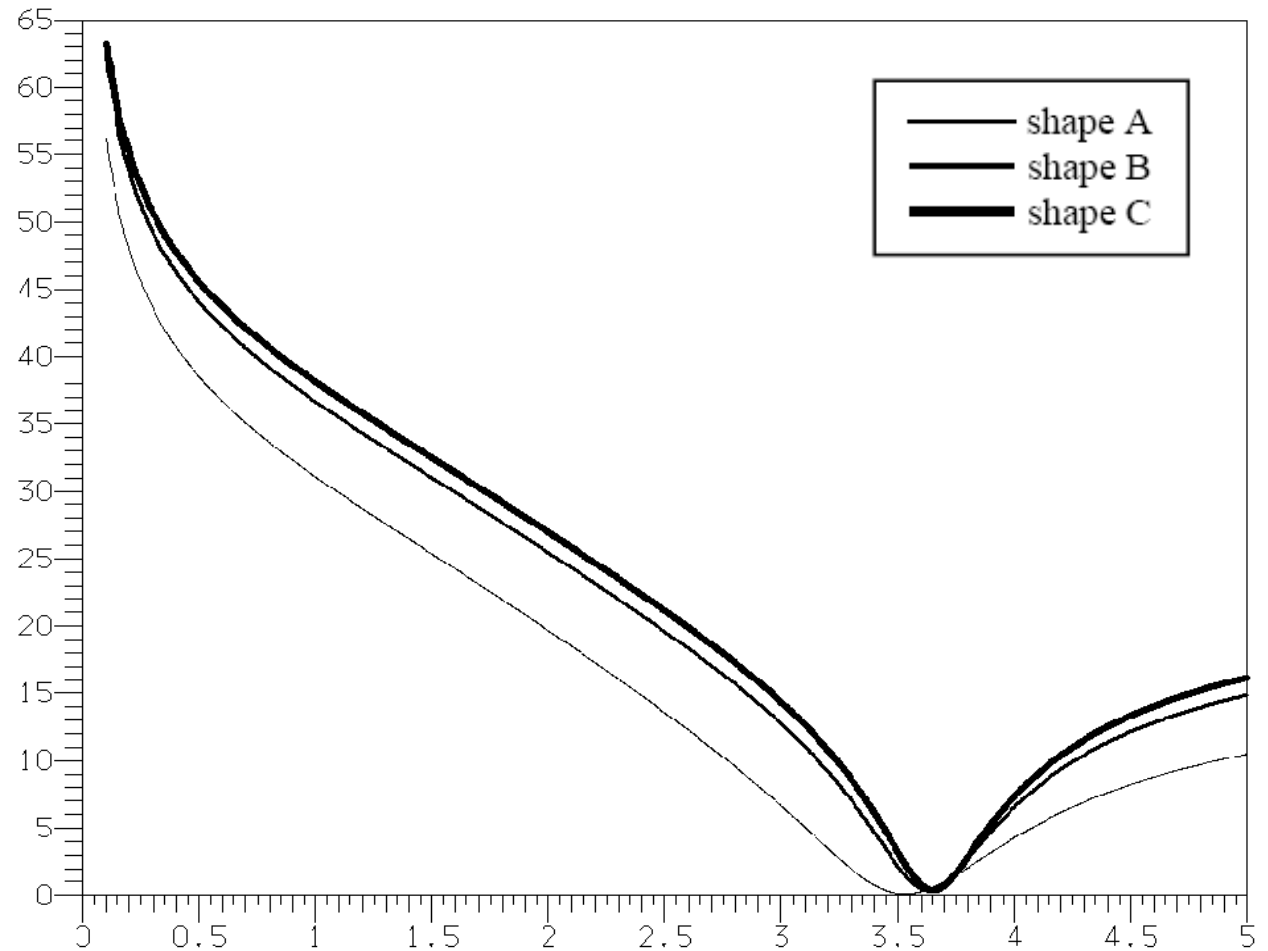
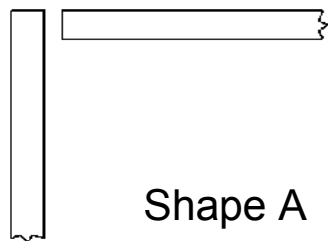
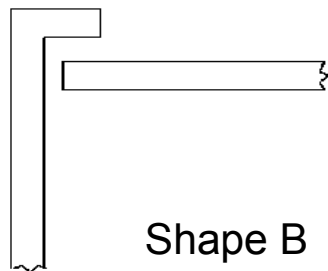
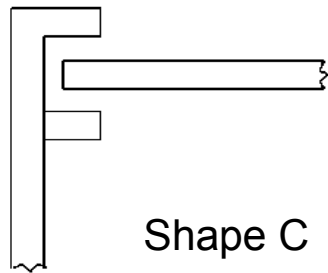

Slot resonant at 3.6GHz, SE at 5 cm away from the slot

Slot Shape and Shielding Effectiveness (TLM)

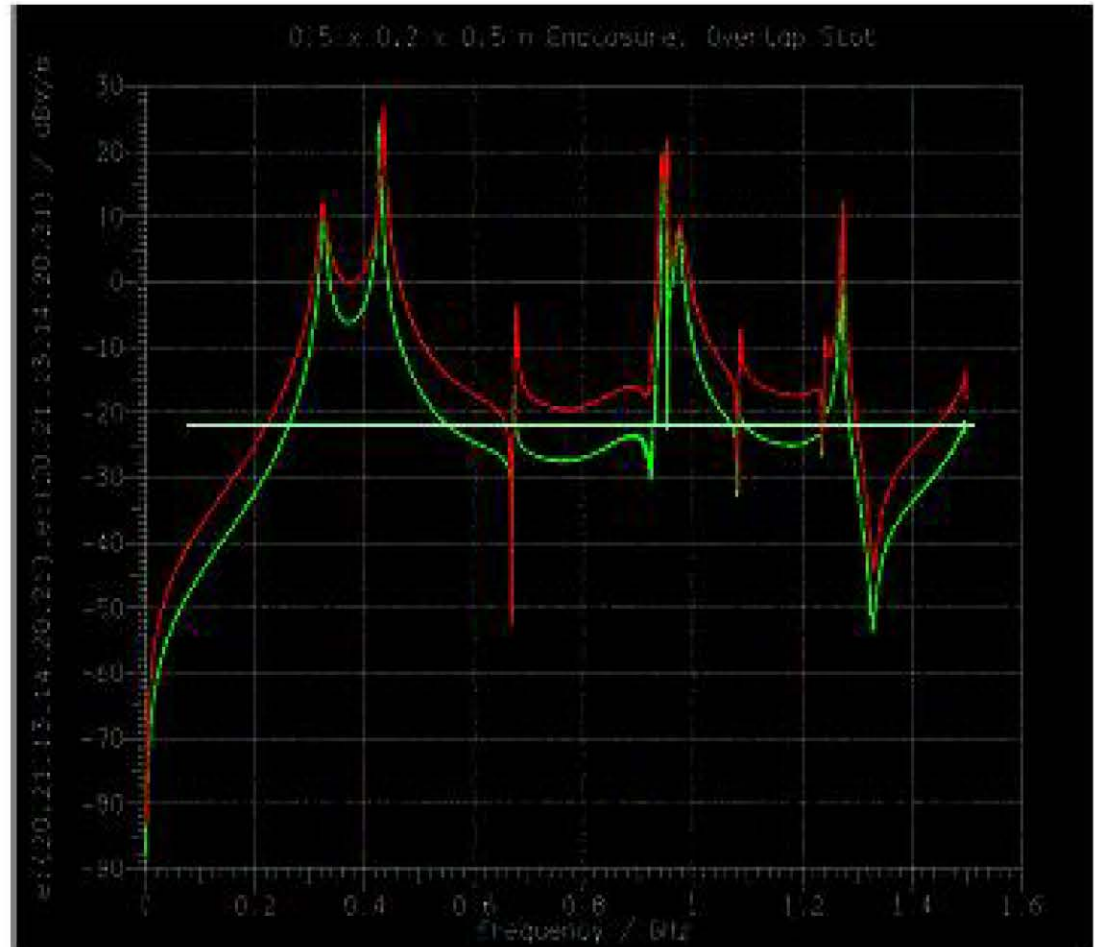
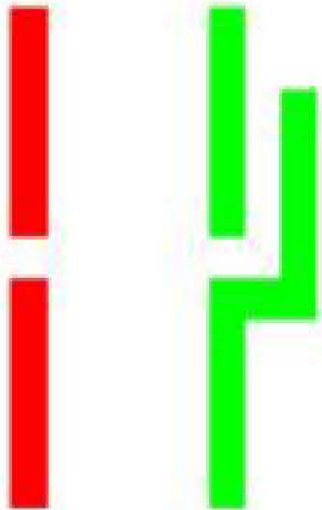
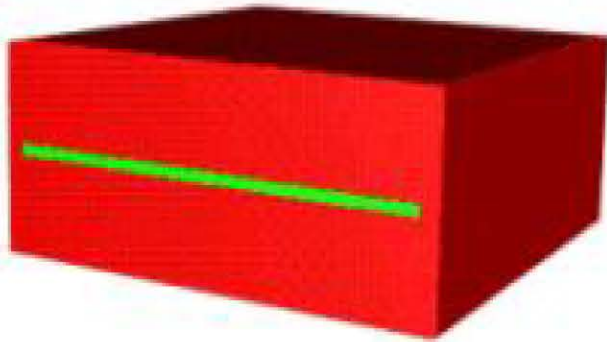

Radiated Emissions - Simulation for a real box with an aperture of different shapes (TLM)

Example of joint treatment for a lid

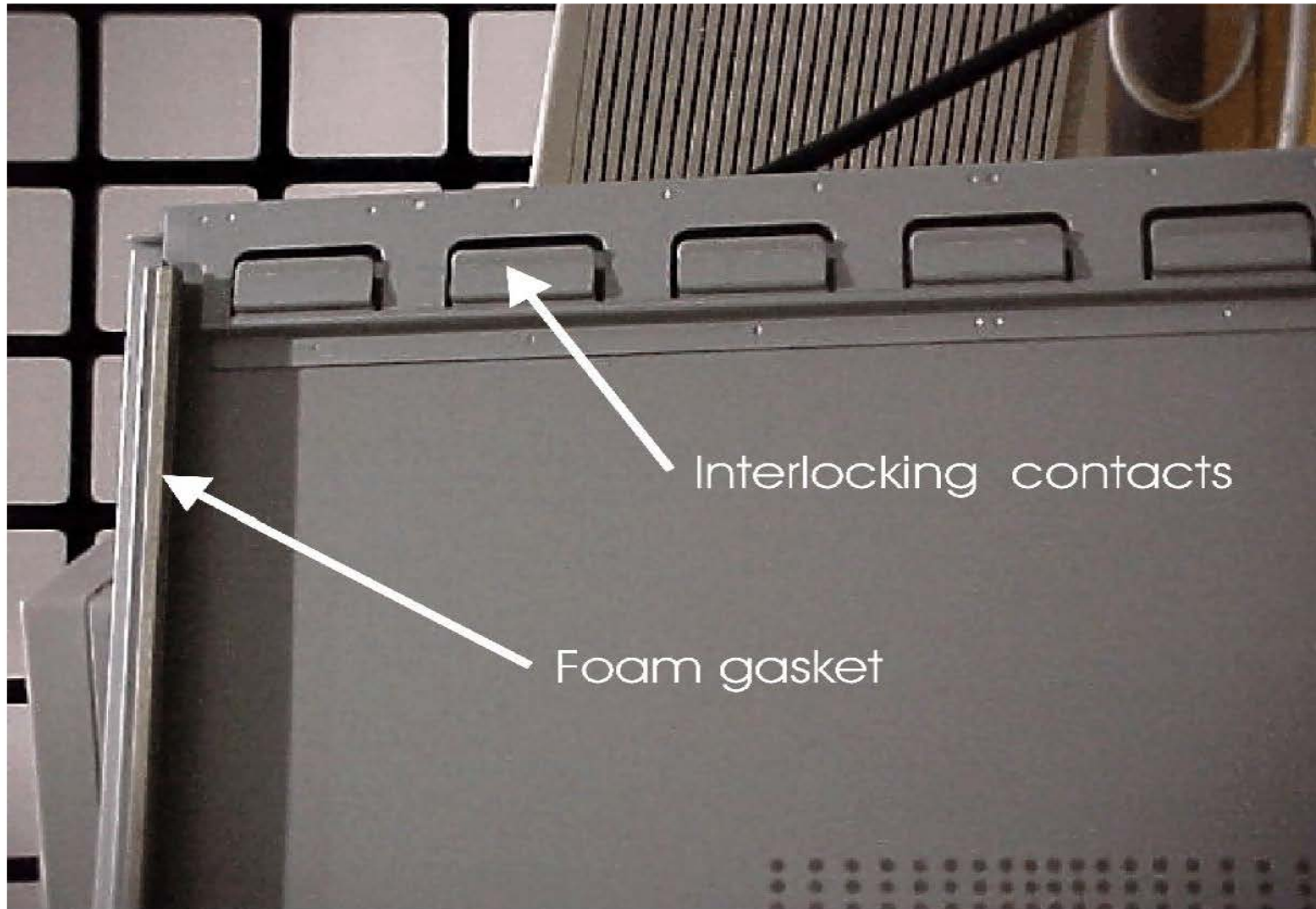

- Can we avoid gaskets?

Type of Joints

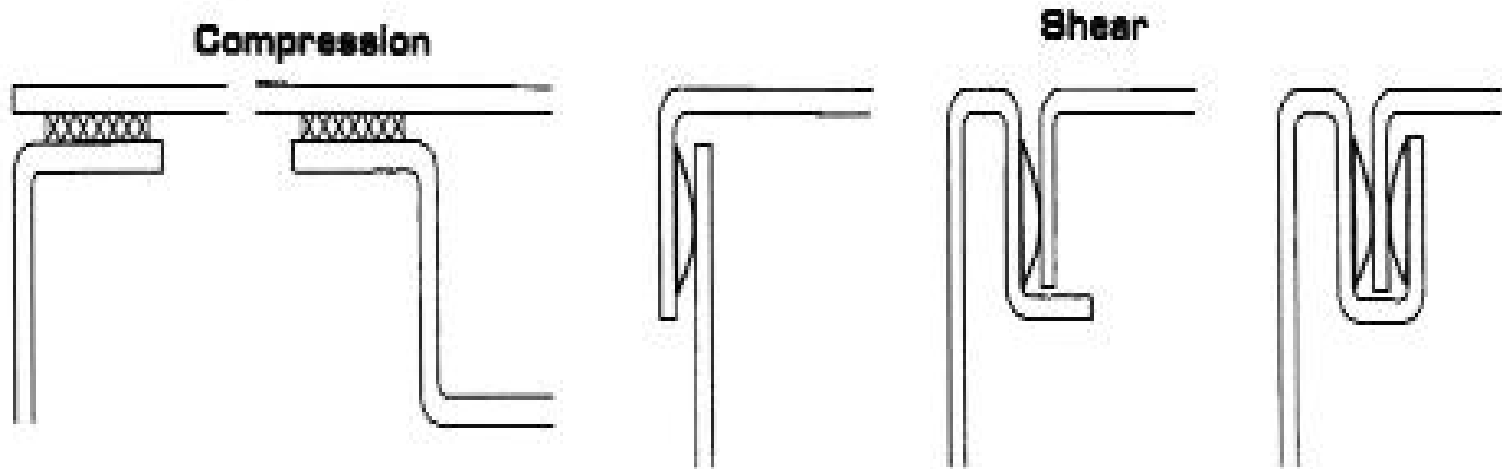

- The type of gasket also critical: fabric over foam, conductive elastomer, conductive foam beryllium-copper spring-fingers (remove oxide), knitted wire, woven fabric, etc.
- Gasket compression is of critical importance (typical 30-70%).
- Need tolerance analysis. Over-compression less a concern than under-compression, however compression stops are recommended.

Gaskets Resistance Between Fasteners

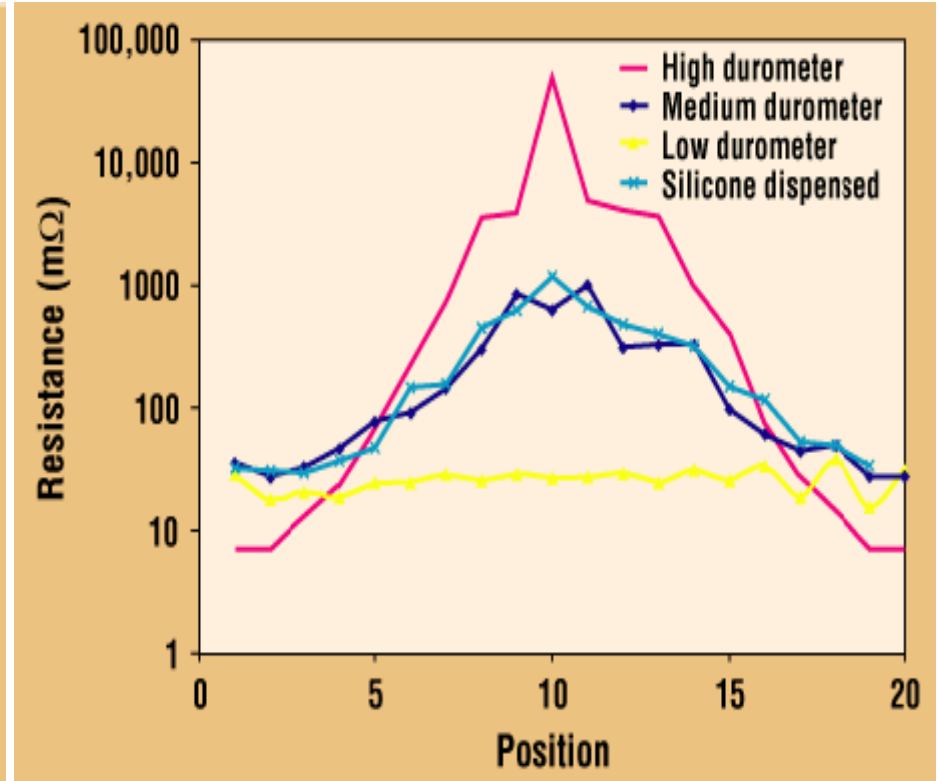
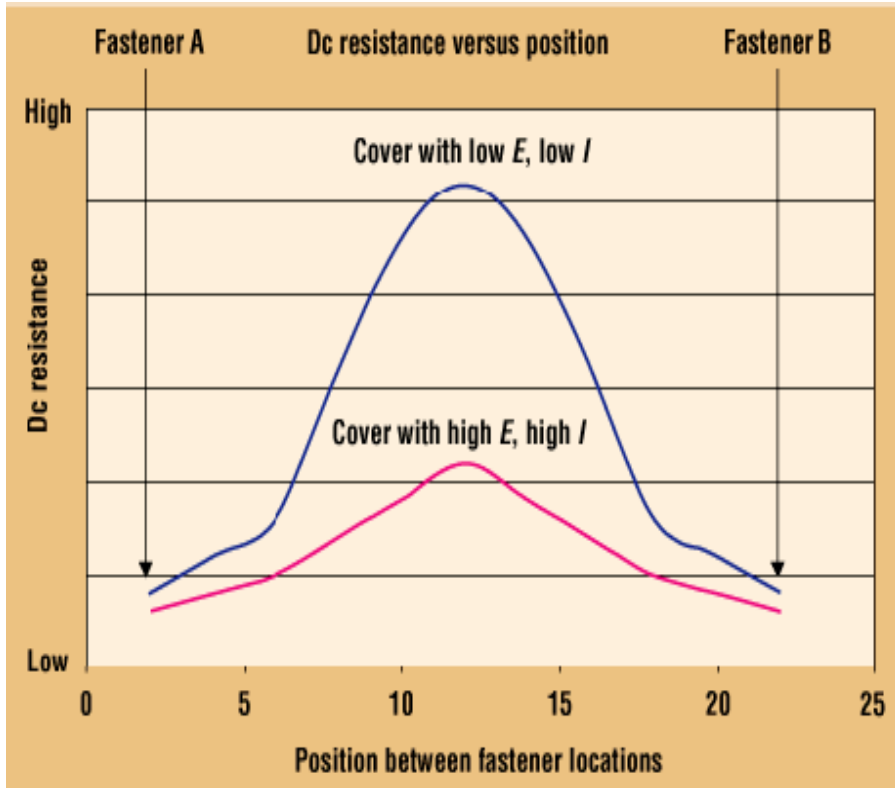

F=force (N), X=distance between fasteners (mm)

E=elasticity module (Steel – 200kN/mm², Plastic – 3kN/mm²)

I=moment of inertia (geometry specific, kg m²)

δ=displacement of a loaded beam (mm)

$$\delta_{max} = \frac{F X^3}{(E) (I) 384}$$

Example of gasketing for a lid and rivets

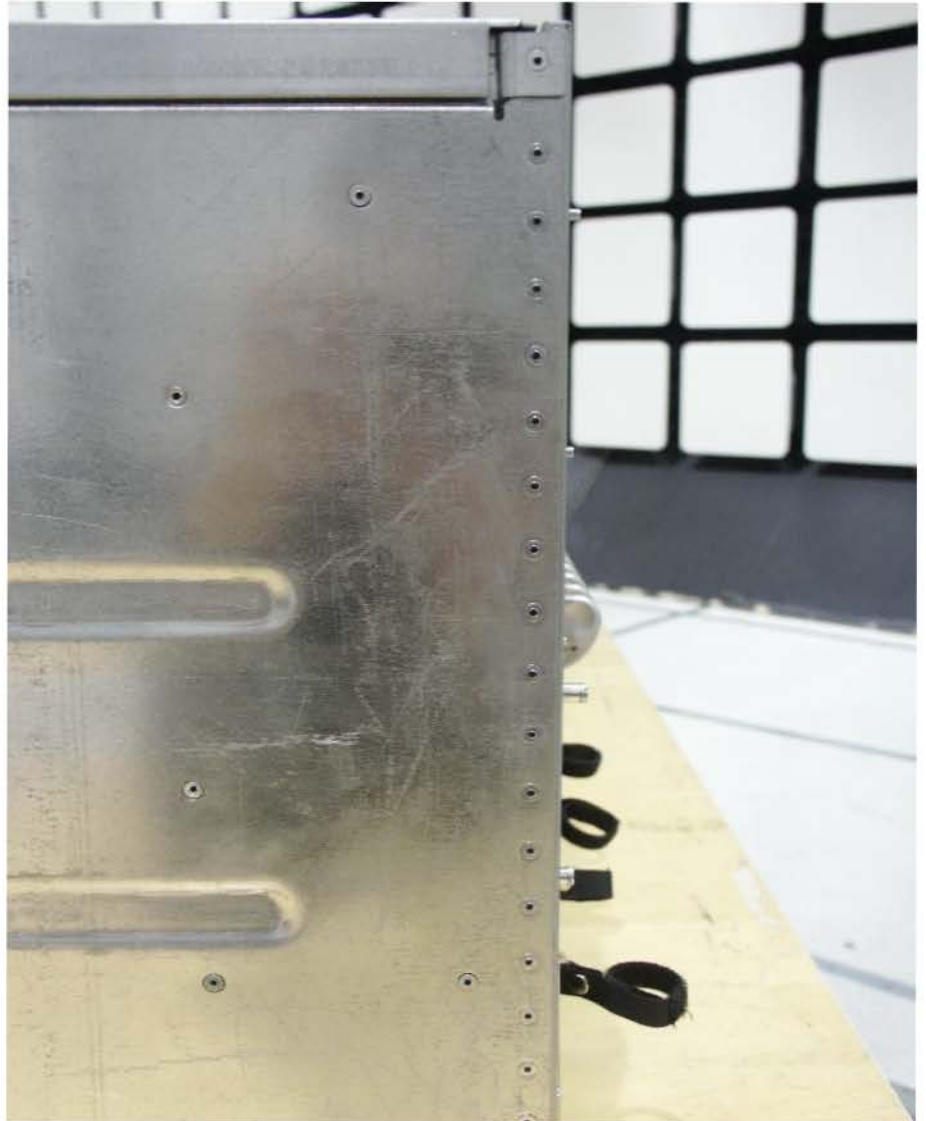

Perf Panel Behavior for EMC and Thermal

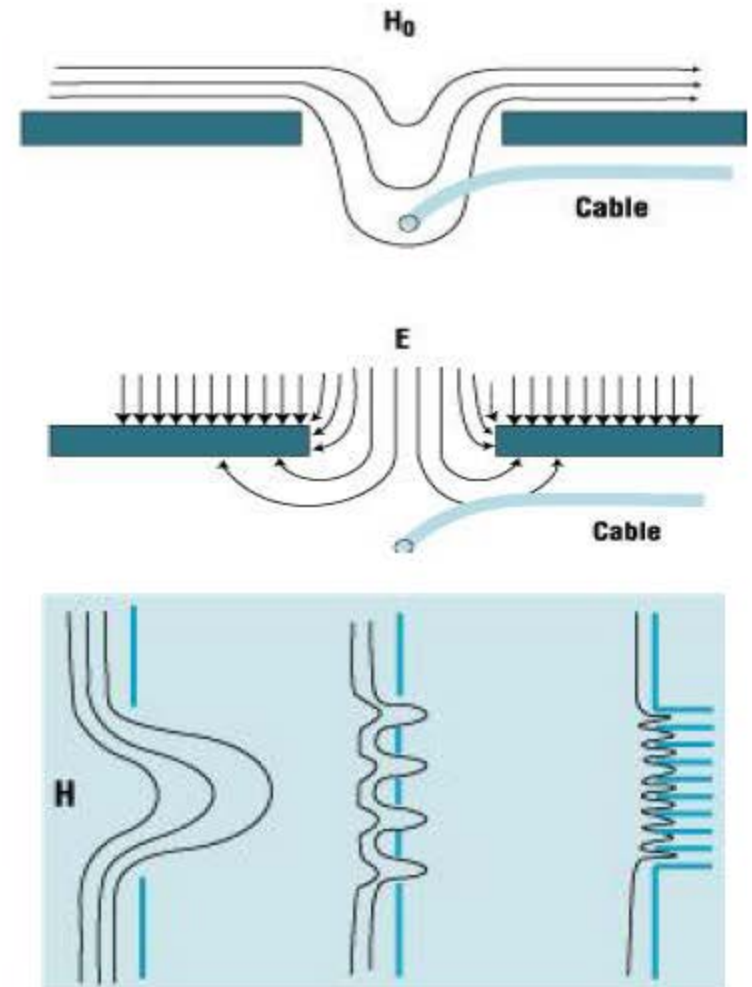
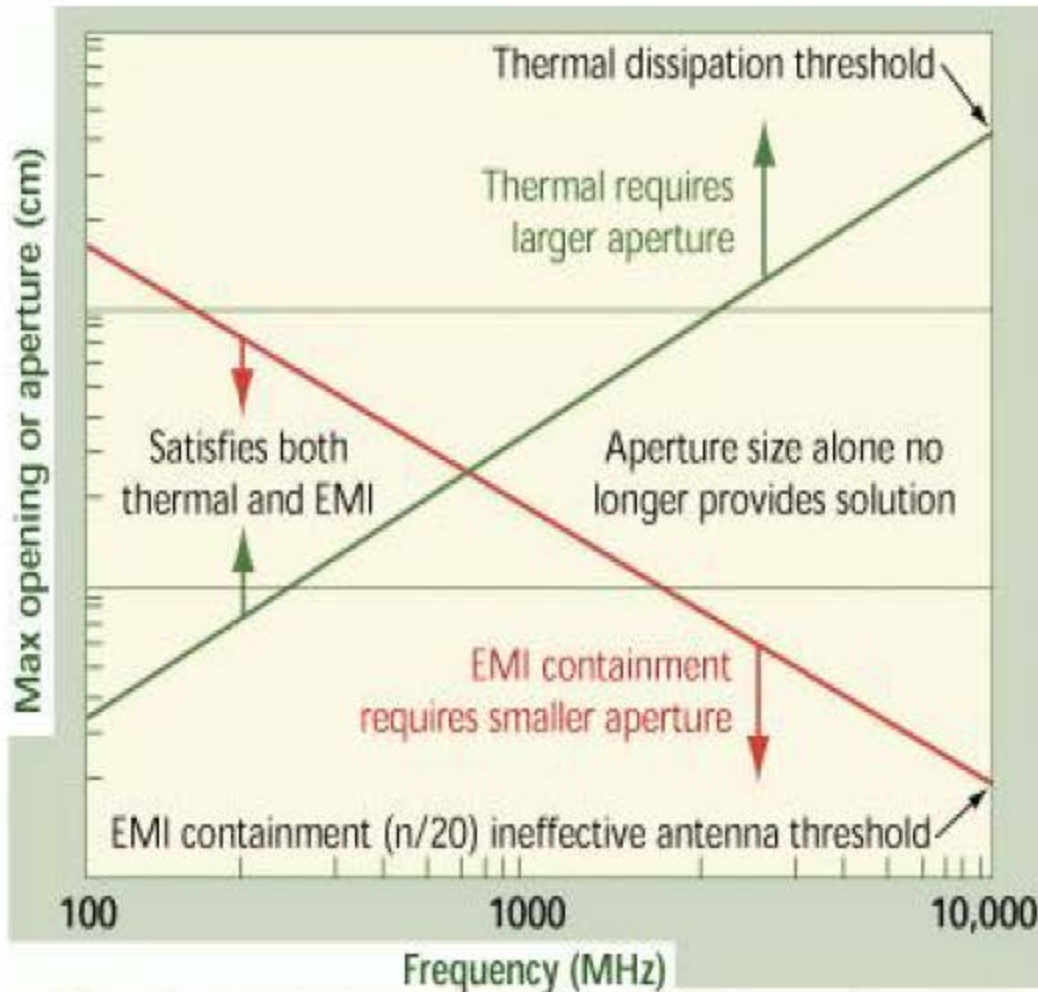

- Thermal has become the main concern (vibration and noise implications)
- Cable management also critical for the EMI performance

Effect of Perf – Wire Coupling on Shielding

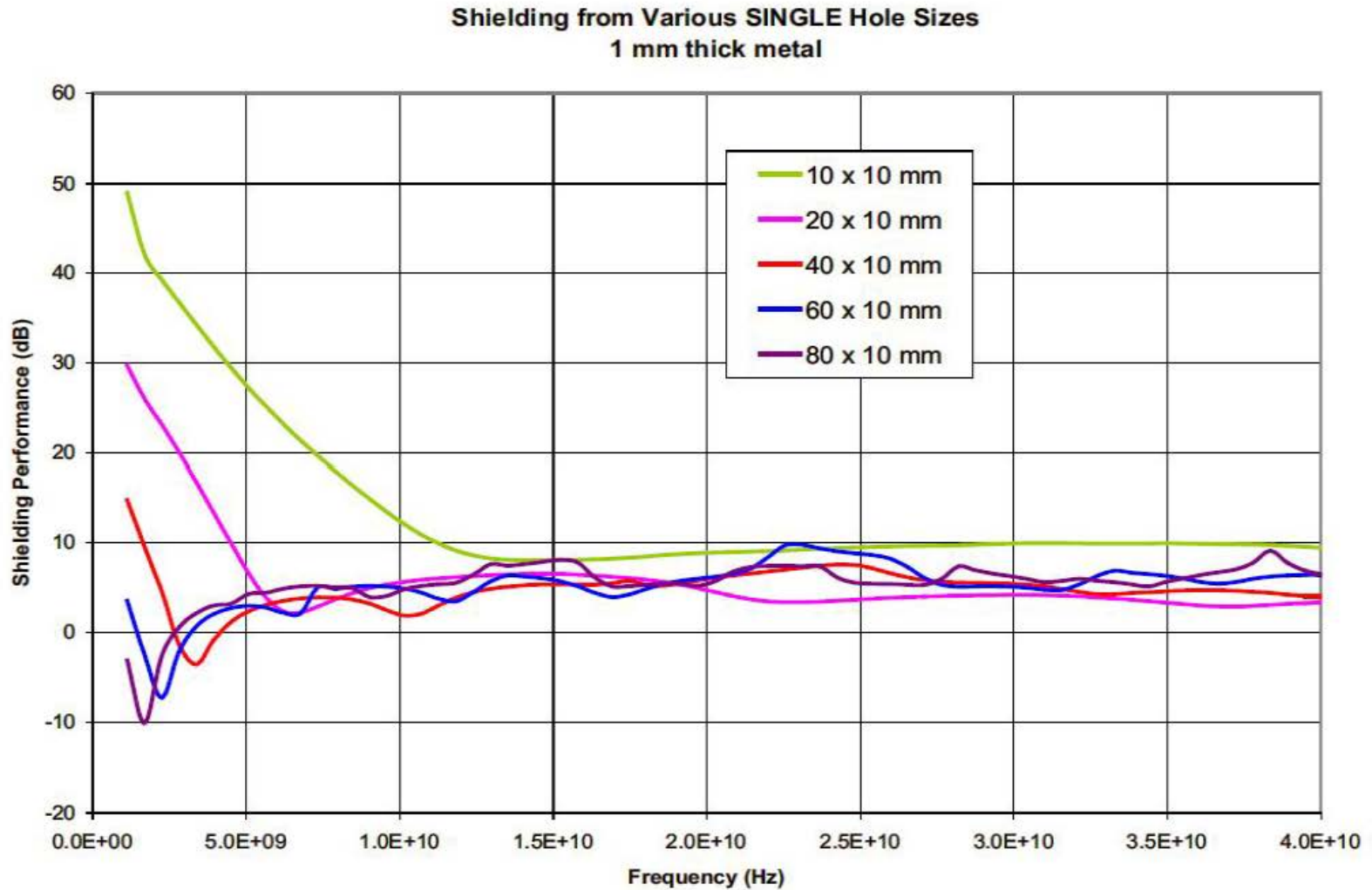

Wire at 20 mm from the hole for single holes

Effect of Perf – Wire Coupling on Shielding

Shielding as Metal Thickness Increases
44 holes @ 4x4 mm with 5 mm Spacing

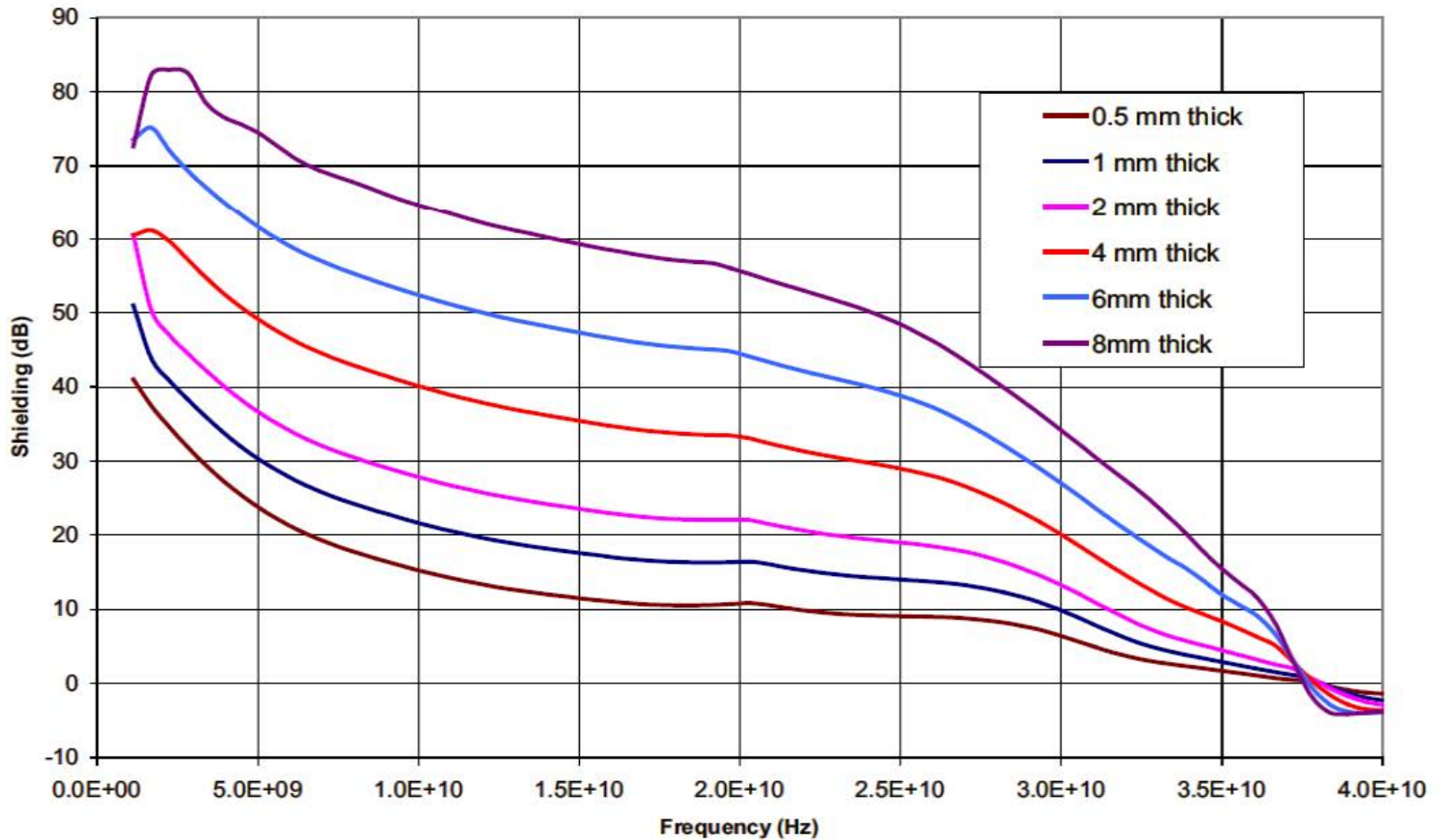

Wire at 20 mm from the hole pattern

Effect of Perf – Wire Coupling on Shielding

Shielding as Metal Thickness Increases
21 holes @ 6x6 mm with 7 mm Spacing

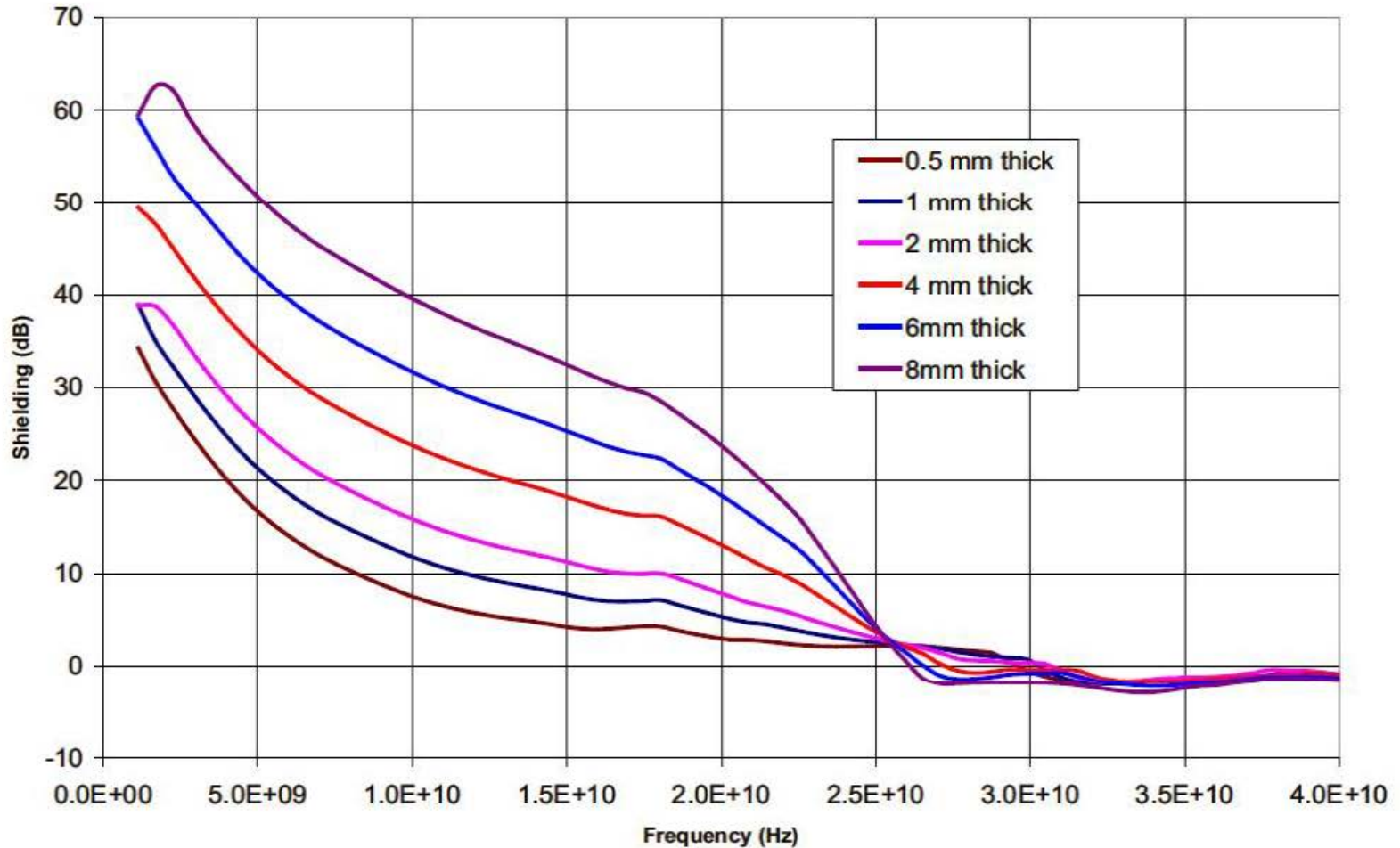

Wire at 20 mm from the hole pattern

Waveguides Below Cut-off

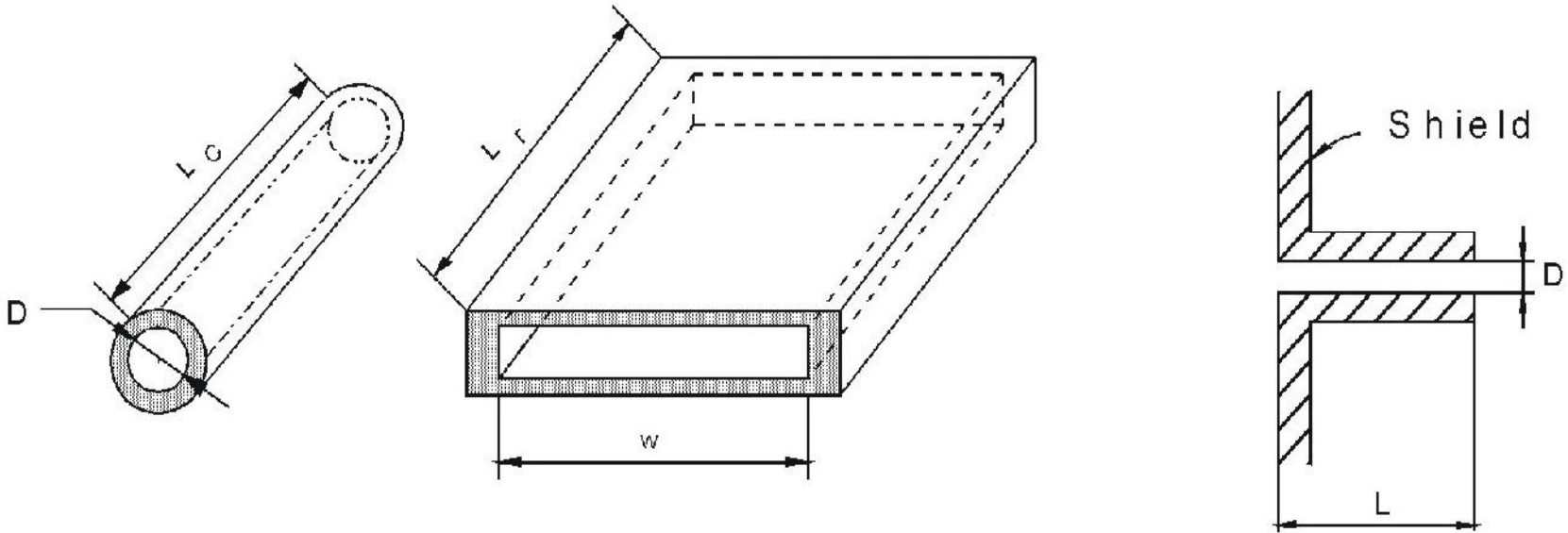

$$f_{cc} = \frac{175.768}{D [m]} [MHz]$$

$$f_{cr} = \frac{150.114}{W [m]} [MHz]$$

$$S.E._c = 32 \frac{L_c}{D} [dB]$$

$$S.E._r = 27.2 \frac{L_r}{W} [dB]$$

$$S.E. \approx 27 \frac{L}{a} - 20 \log_{10} N [dB]$$

- For Honeycomb:

where: a - the largest waveguide transverse dimension, L – the length of the waveguide, and N – the number of waveguides employed in the honeycomb

- Never pass a wire through a waveguide below cutoff (will support TEM mode)

Waveguides Below Cut-off

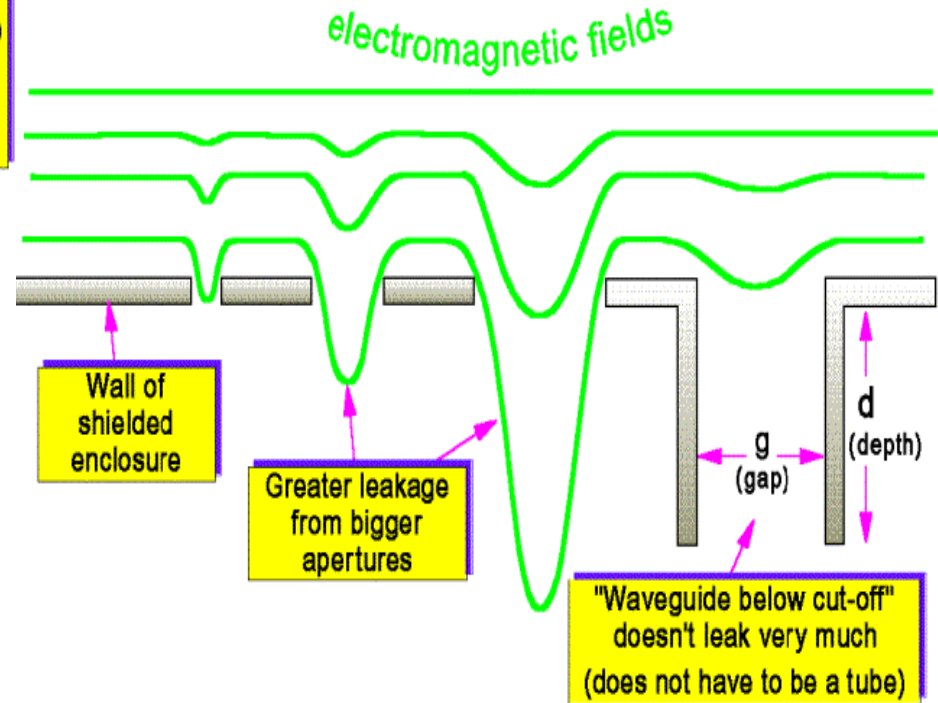
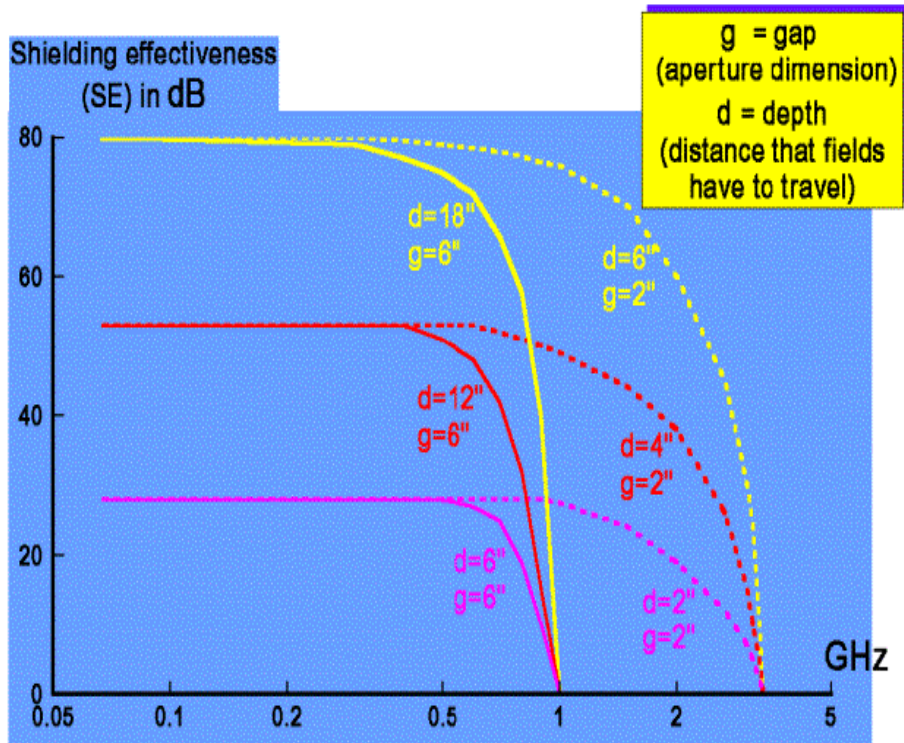

$$F_c \text{ [GHz]} = 5.9/g \text{ [inches]}$$

g = gap, largest transverse dimension

$$SE \text{ [dB]} = 27.2 d/g$$

d = depth, length of the waveguide

Honeycomb – Air Pressure Drop and SE

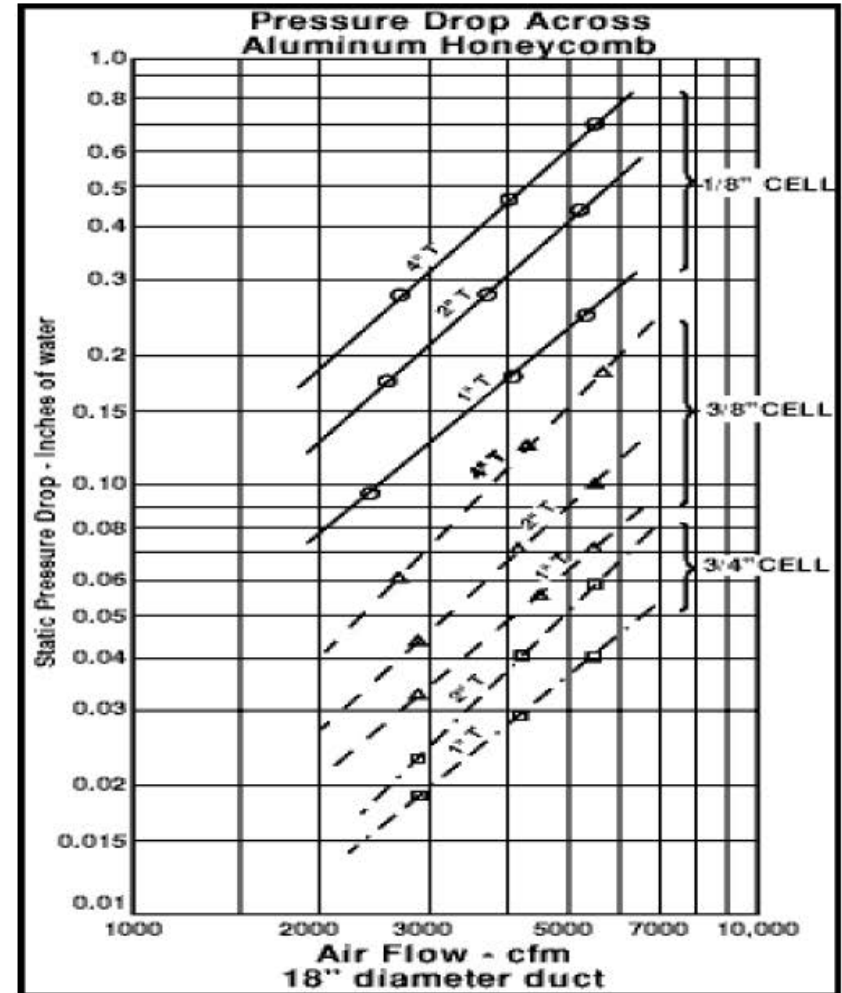
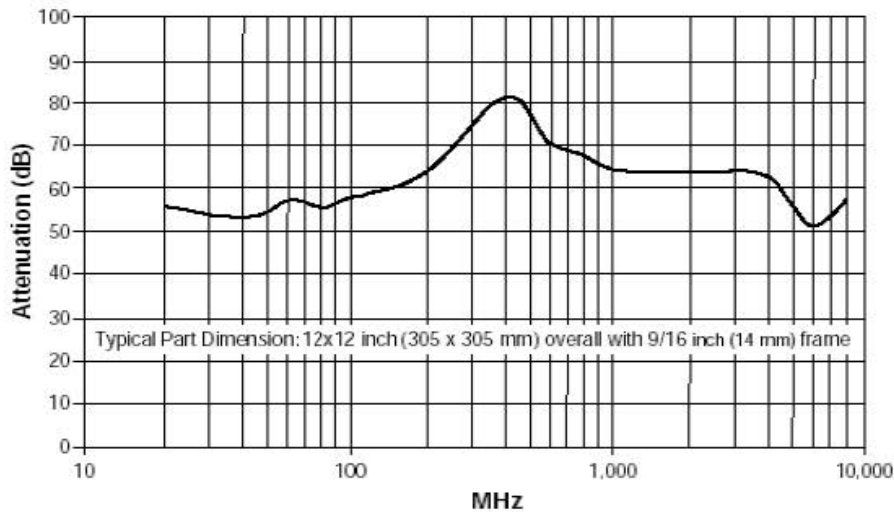
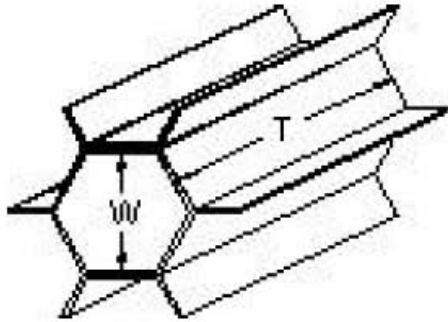

T = length of the waveguide, depth

W = the largest transverse dimension

Honeycomb – The Effect of Polarization

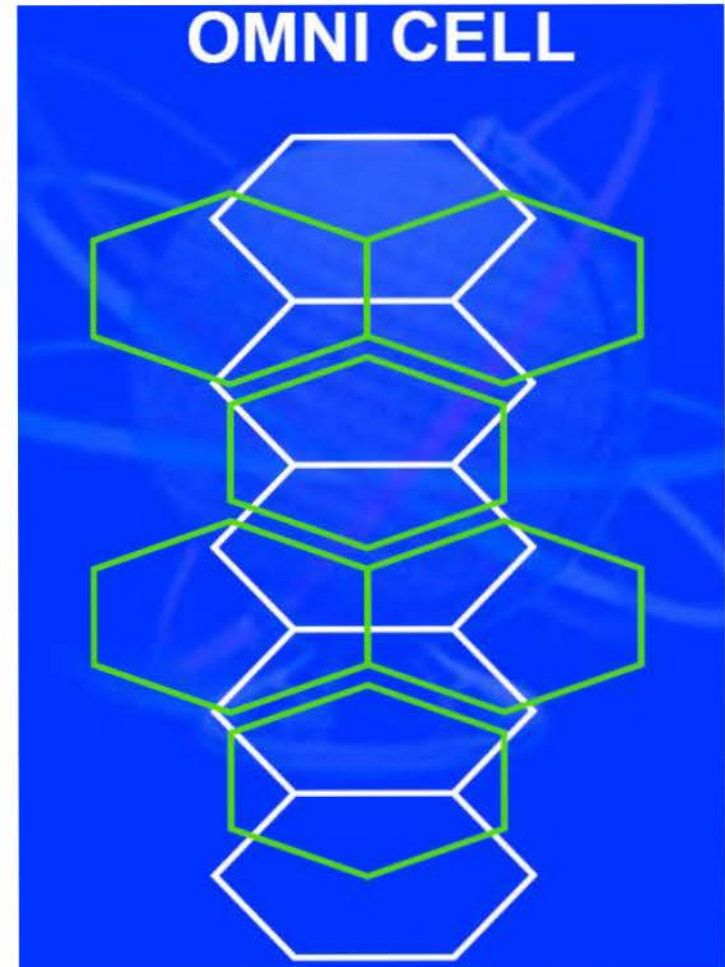
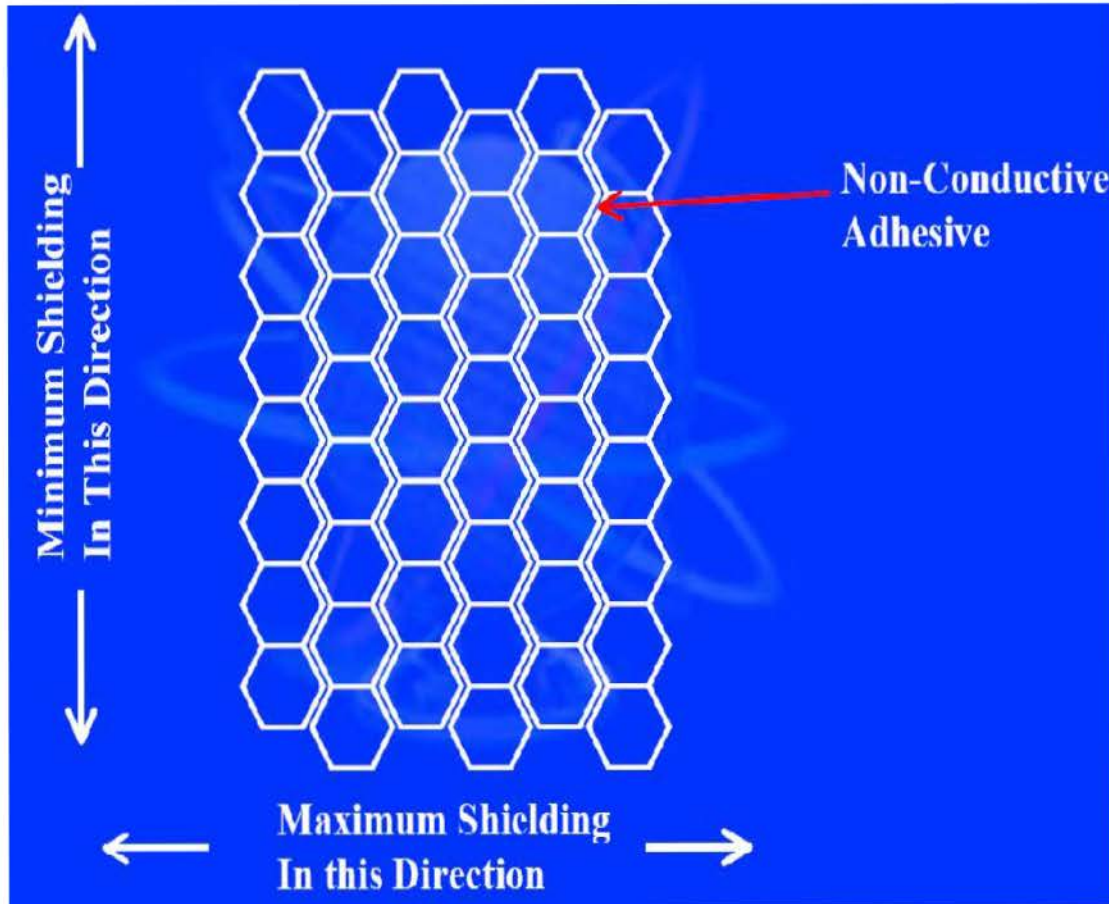

- For single layer, non-plated honeycomb, the SE can be up to 40dB better in one direction
- Omni Cell (Chomerics) uses two layers of honeycomb at 90 degrees of each other

An Example: Single Layer 1/4" Honeycomb

Airflow/Pressure Drop Data

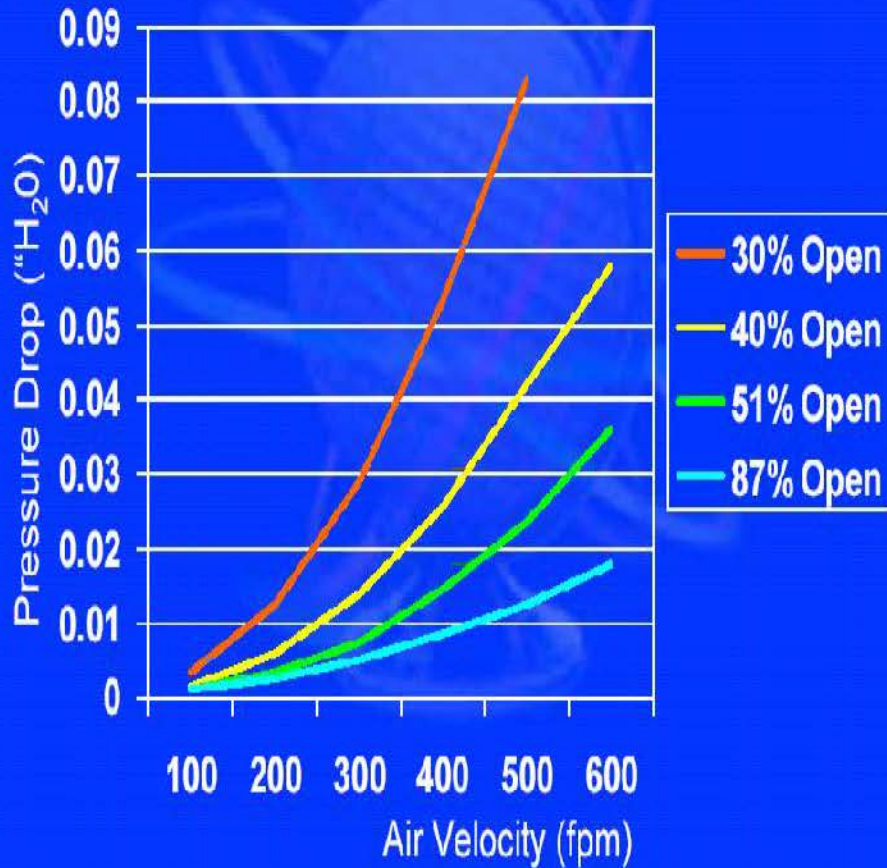

Single layer Un-plated 1/4" honeycomb

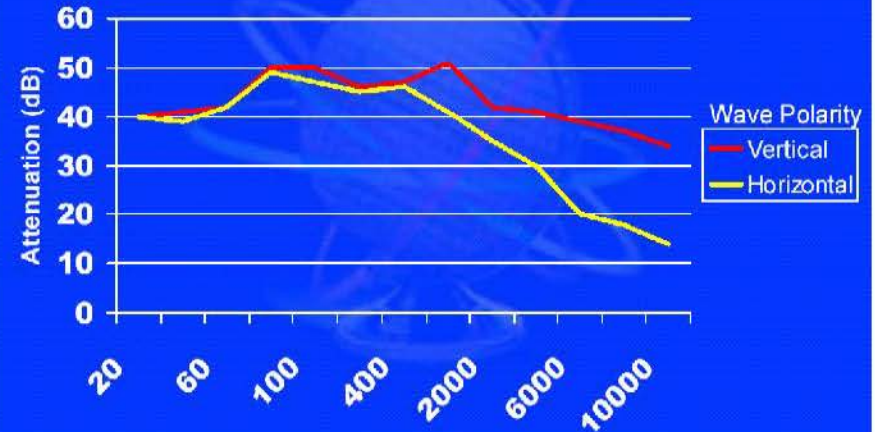

Single layer plated 1/4" honeycomb

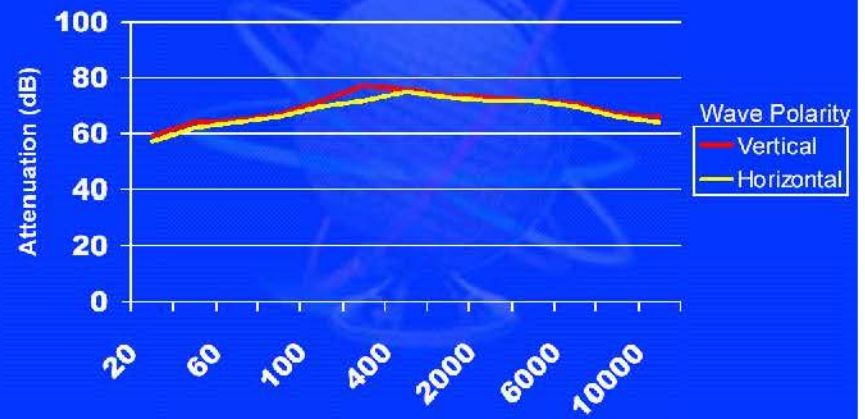

Honeycomb Frames & Gaskets

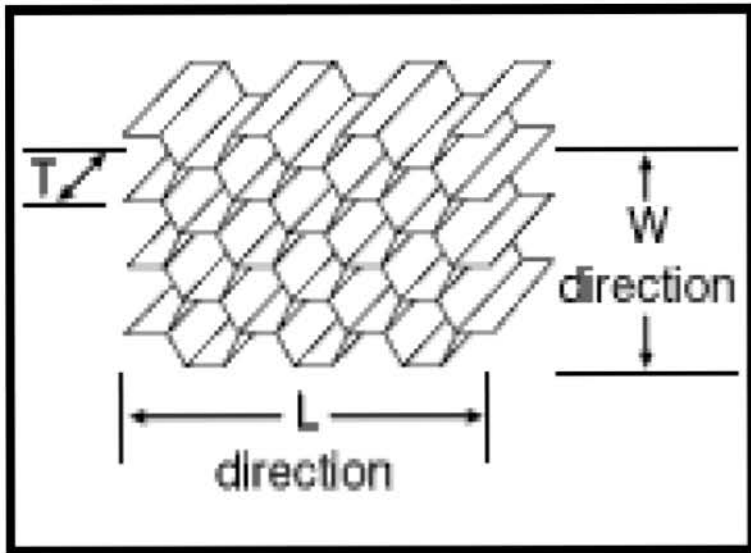
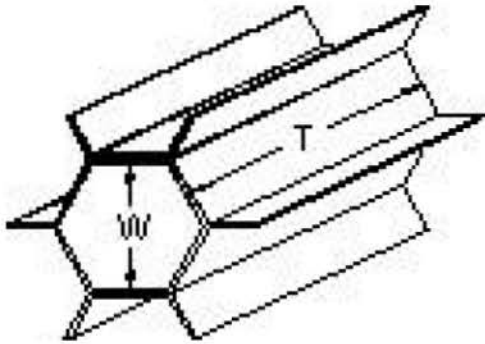

T = length of the waveguide, depth



Perf Panel Example

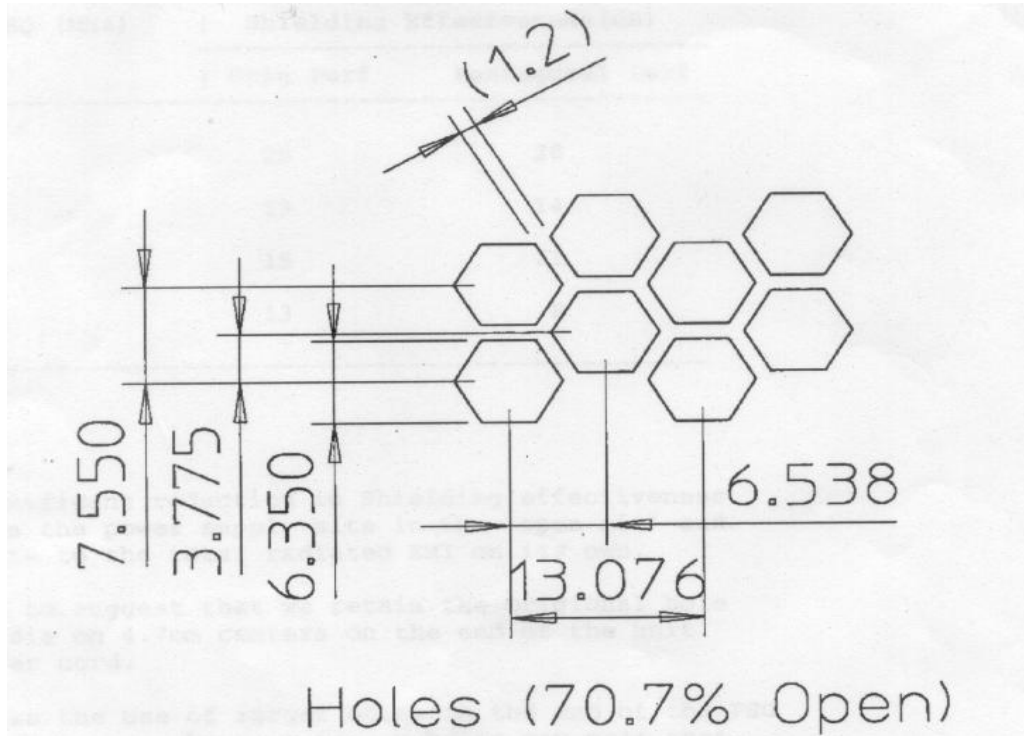

SE = 8dB @ 1.2GHz

(Type of perf pattern used
in some power supplies)

For staggered round holes with
4mm diameter, and center to
center distance of 4.7mm, for a
92x206mm panel:

SE = 13dB @ 1.2GHz

It gets worse if the frequency,
diameter or panel dimensions
increase, or if center distances
decrease.

For a 1/4" plated honeycomb
with less than 1/4" cells:

SE > 50dB @ 10GHz

Typical Perf Used for Cosmetic Areas

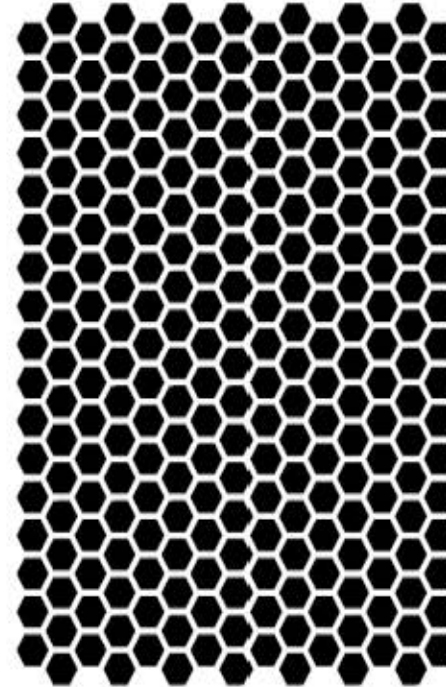
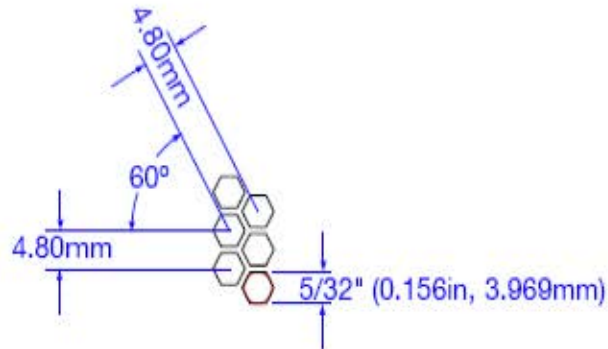

The 5/32" hex perf pattern is a standard one and should be readily available wherever it needs to be manufactured.

Single and Double Perf Panels

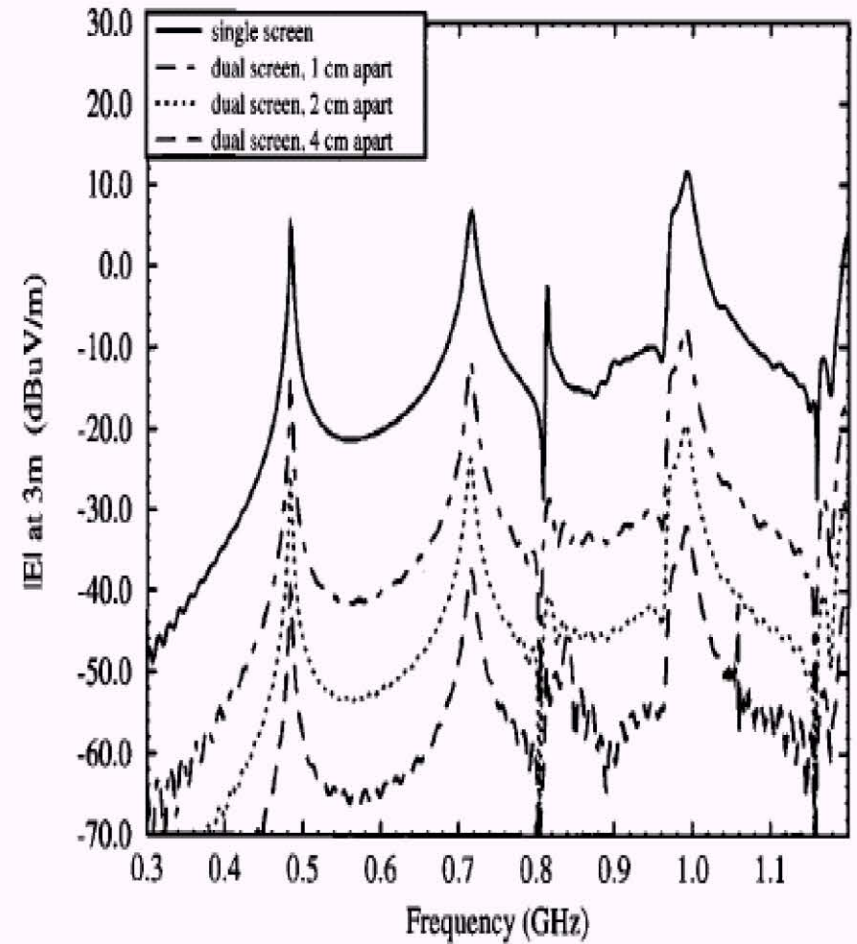
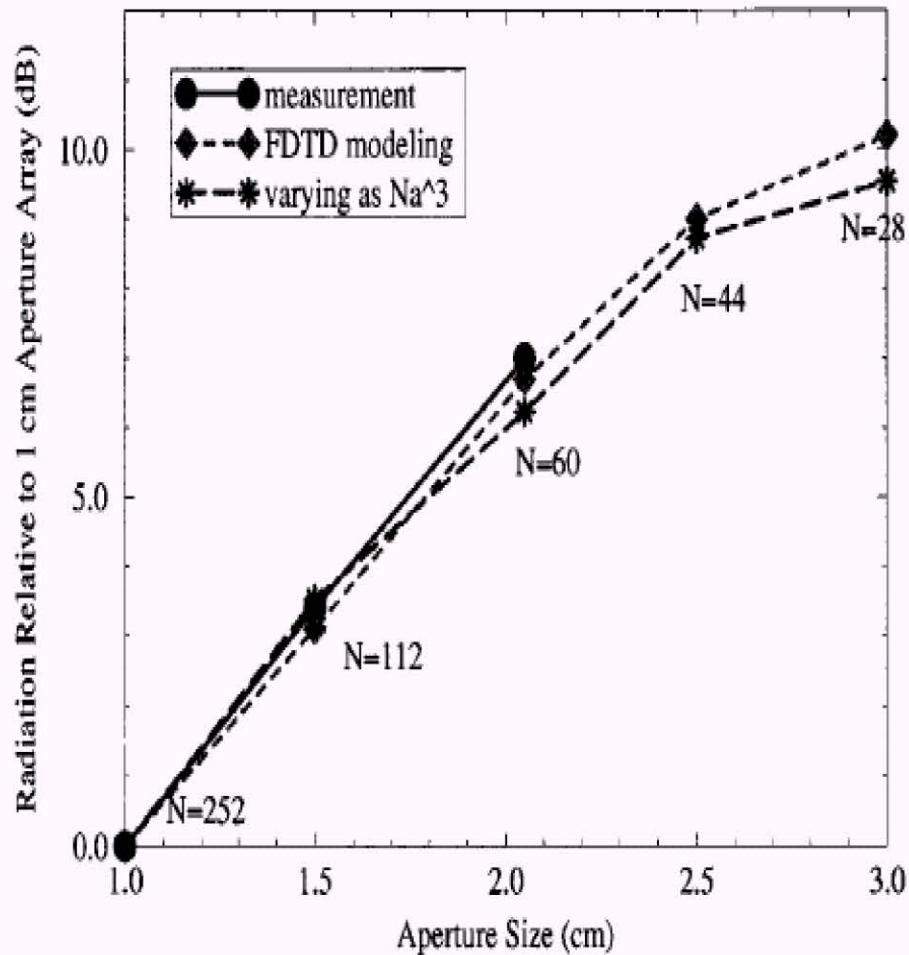

An Example: Double Perf Panels

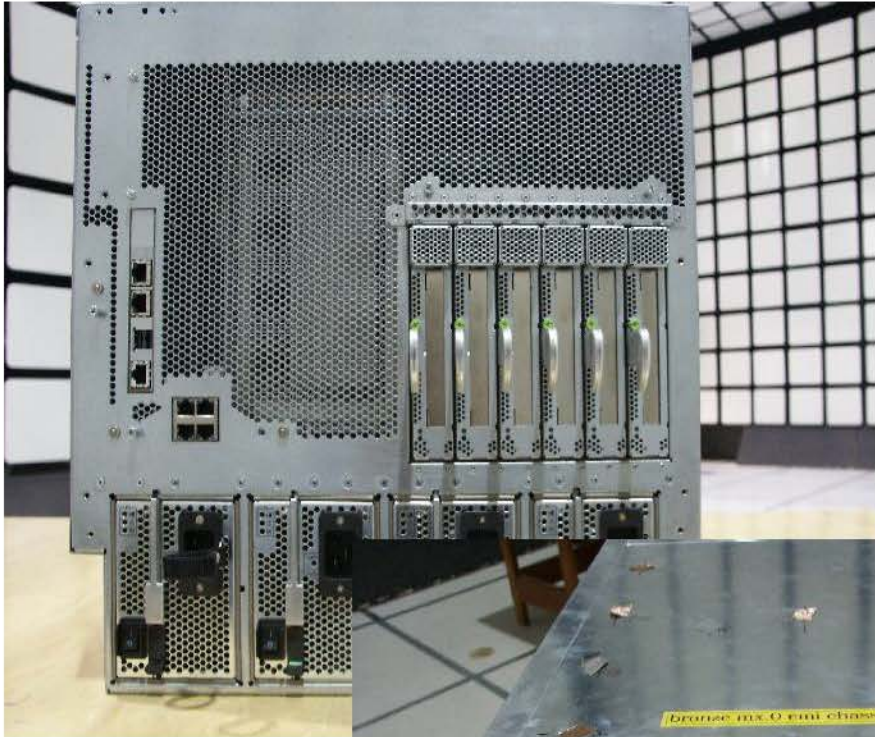

Know Your Noise Source: CPU Radiated Emissions

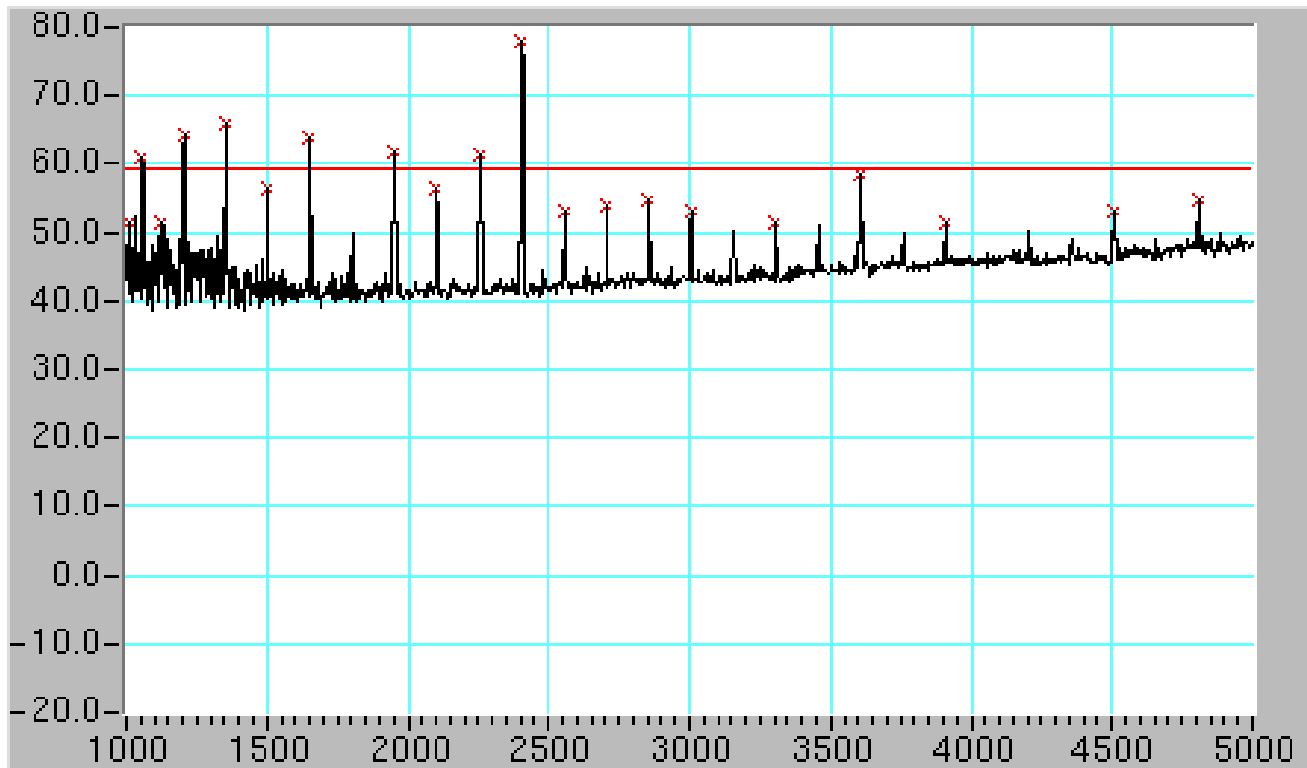

- Open Chassis Emissions for a 1xCPU@1.2GHz) (older system).
Average: 18.6dB over Class A.

EMI mechanisms for VLSI chips

- The Heatsink acting as a monopole antenna against the first solid plane of the PCB (tall Heatsink).
- The Heatsink and the first solid plane of the PCB creating a patch antenna (wide Heatsink).
- The low inductance power distribution of the VLSI chip allows noise injection into the PCB, which re-radiates (especially through closely placed DC-DC converters).

Typical problems with heatsink grounding

- Components on Top need to be placed at a distance (some decoupling may be impacted)
- No pin escapes on Top
- The routing might be impacted by the multiple vias from the GND ring to GND plane
- Not effective above approx. 1GHz (any grounding will be too inductive to really matter)
- No direct DC grounding if the chip can use Back Bias or Forward Bias

Heatsink as a Monopole and Cavity Resonance

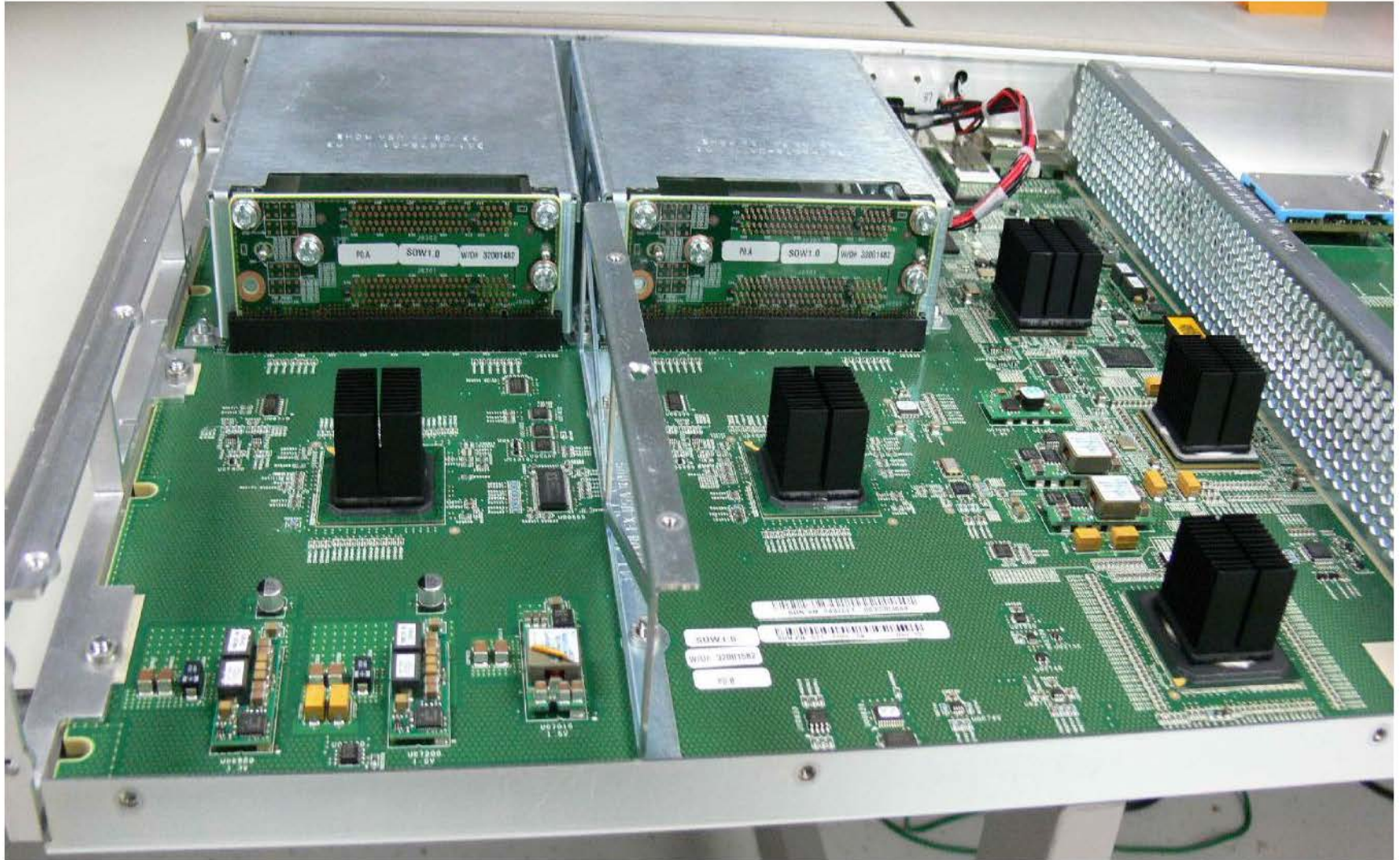

Heatsink radiation at 5GHz from PCI_e Switches

Heatsink as a Monopole and Cavity Resonance

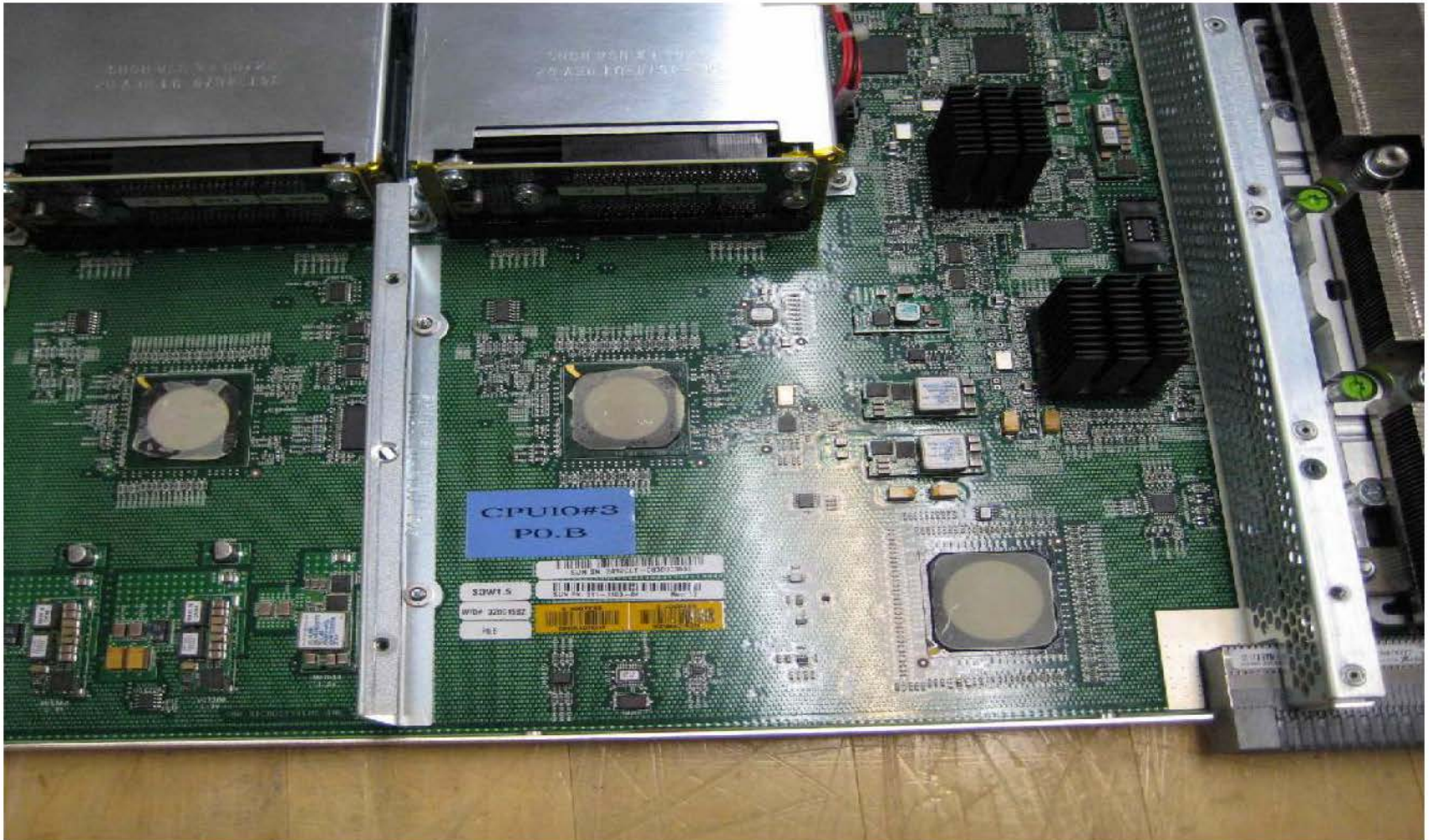

Removing the heatsinks from the PCI_e switches, 5GHz decreases 58

Heatsink as a Monopole and Cavity Resonance

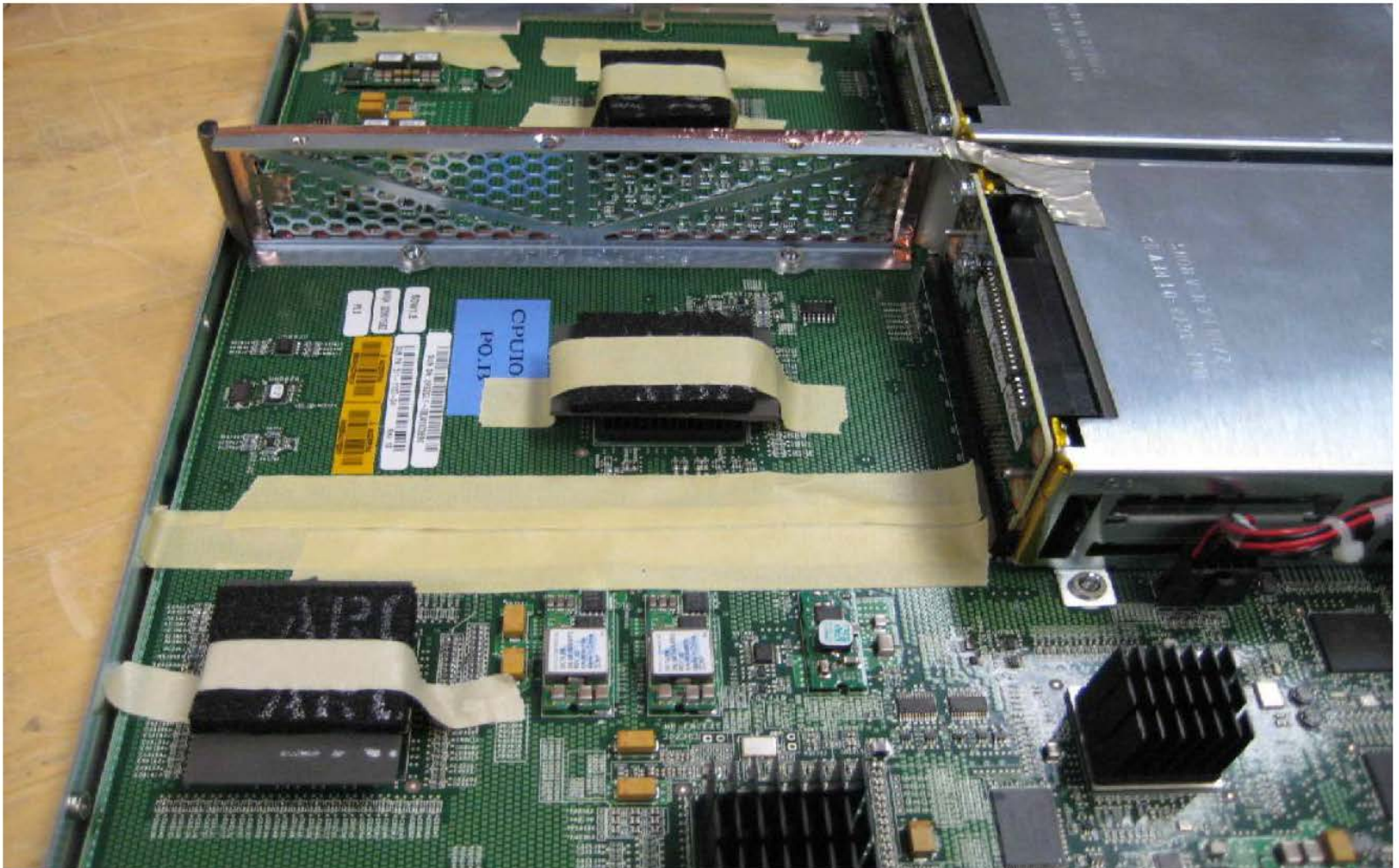

Adding carbon loaded foam over the heatsinks of the PCI_e Switches ⁵⁹

Electromagnetic Wave Absorbers

- Electromagnetic wave absorption materials absorb the energy in electromagnetic waves as resistive, dielectric or magnetic losses, and convert that energy, in the end, to heat. The amount of that absorption, P , can be expressed by the following formula:

$$P = P_{\sigma} + P_{\epsilon} + P_{\mu} = \frac{1}{2} \sigma |E|^2 + \frac{1}{2} \omega \epsilon_0 \epsilon_1'' |E|^2 + \frac{1}{2} \omega \mu_0 \mu_1'' |H|^2$$

P [W/m ³]:	Electromagnetic energy absorbed per unit volume
E [V/m]:	Electric field strength of the incident electromagnetic radiation
H [A/m]:	Magnetic field strength of the incident electromagnetic radiation
σ [S/m]:	Conductivity of the material
ω [sec ⁻¹]:	Angular speed of the electromagnetic wave (= $2\pi f$)
ϵ_r'' :	Complex component of the dielectric constant of the material
ϵ_0 [F/m]:	Dielectric constant of the vacuum: 8.854×10^{-12} [F/m]
μ_r'' :	Complex component of the dielectric constant of the material
μ_0 [A/m]:	Magnetic permeability of the vacuum: 1.2566×10^{-6} [H/m]

Heatsink as a Patch Antenna

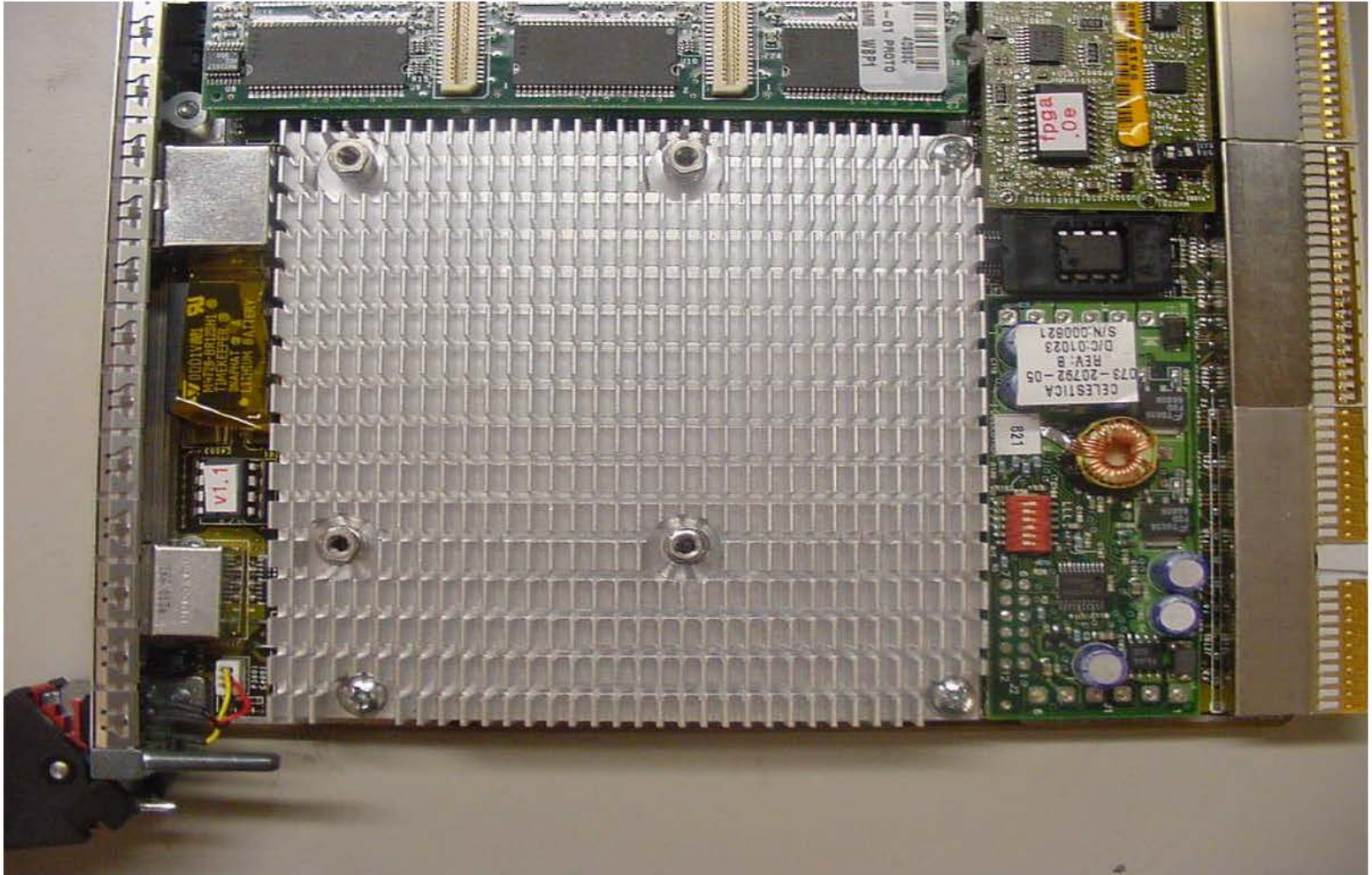

- Example of heatsink cavity resonances -Compact PCI

VLSI injecting noise into the PCB

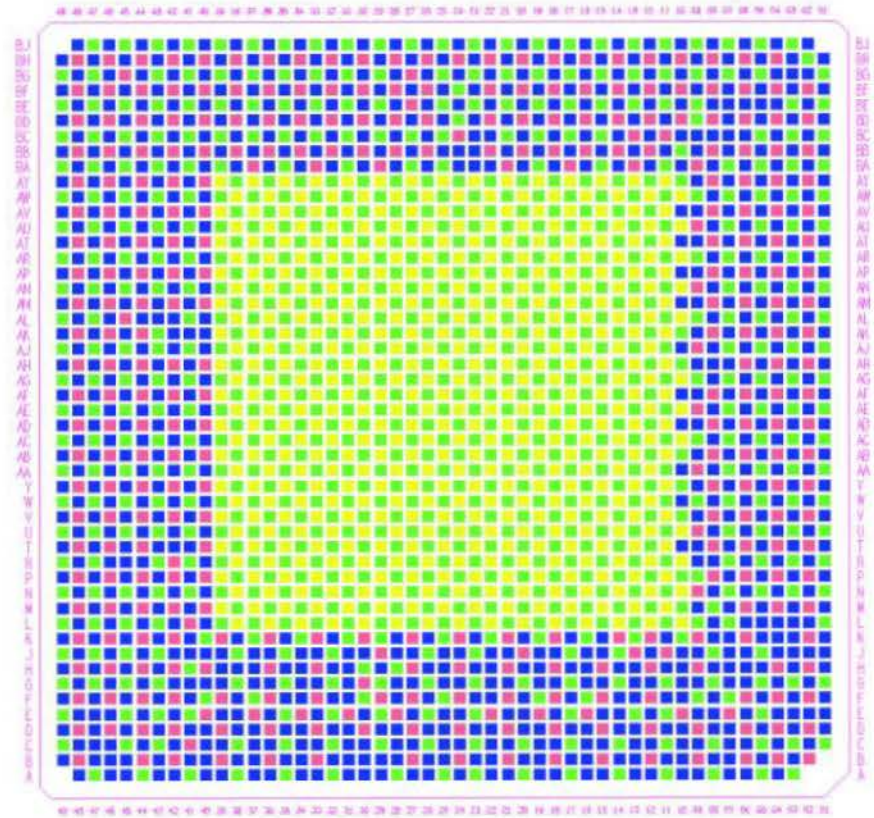
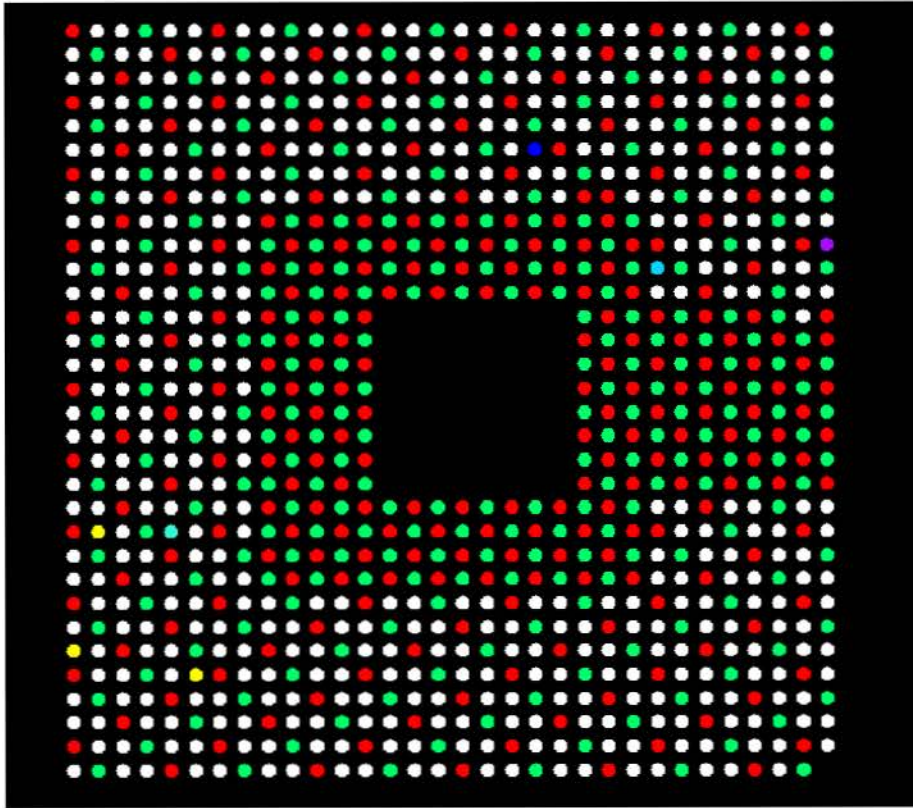

- μ PGA (more inductive) and LGA (less inductive)

Heatsink: Grounding vs. Shielding

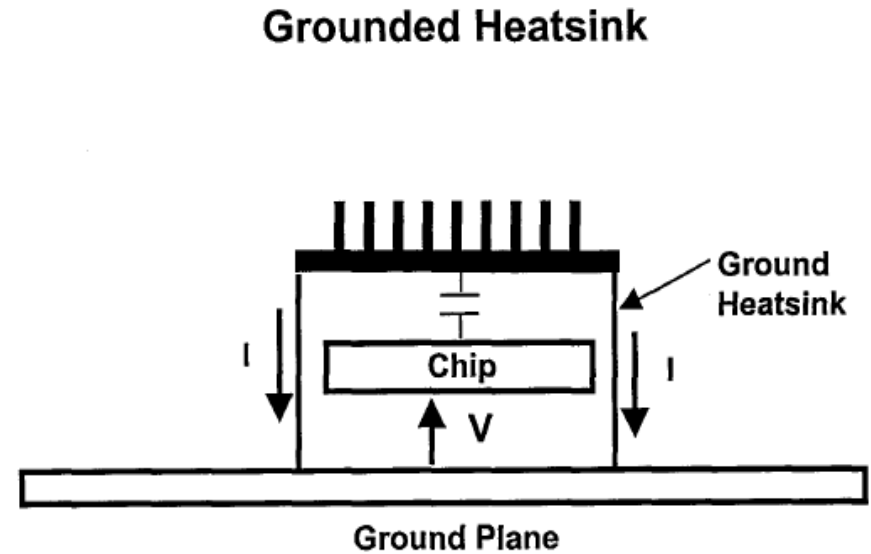
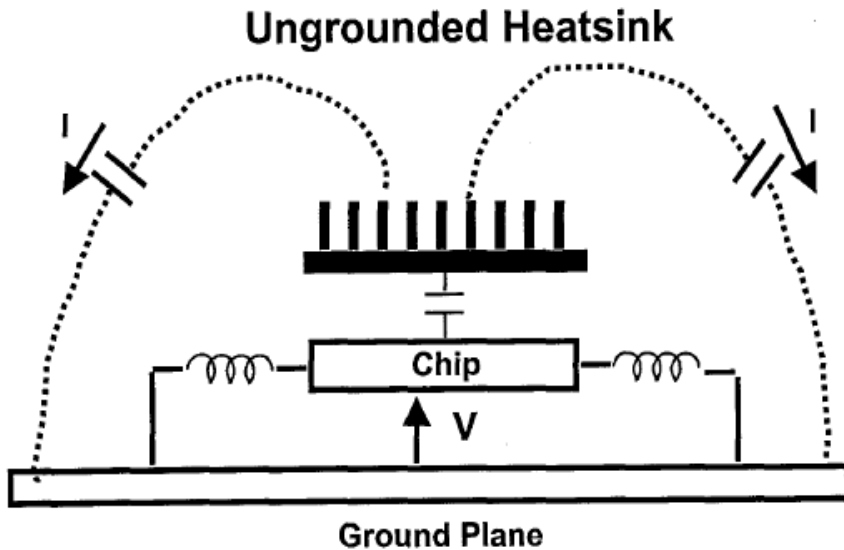

Heatsink Should be Grounded With Multiple Connections to Ground on Each of the Four Sides of the Heatsink

- Grounding will work at lower frequencies, but not above 1GHz
- Heatsink shielding works at higher frequency (grounding is implicit) if the contact is continuous, 360 degrees, creating a Faraday cage.

Typical Heatsink Grounding and Shielding

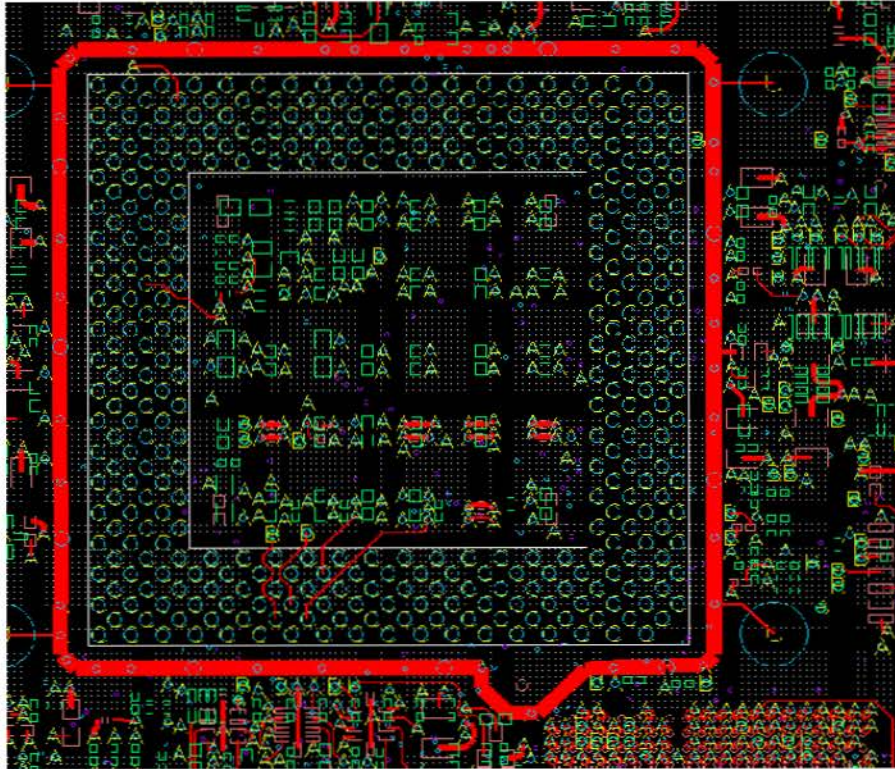

- Grounding ring and EMI gasket on top layer PCB

Example: UltraSPARC IIIe in Sun Ultra 60

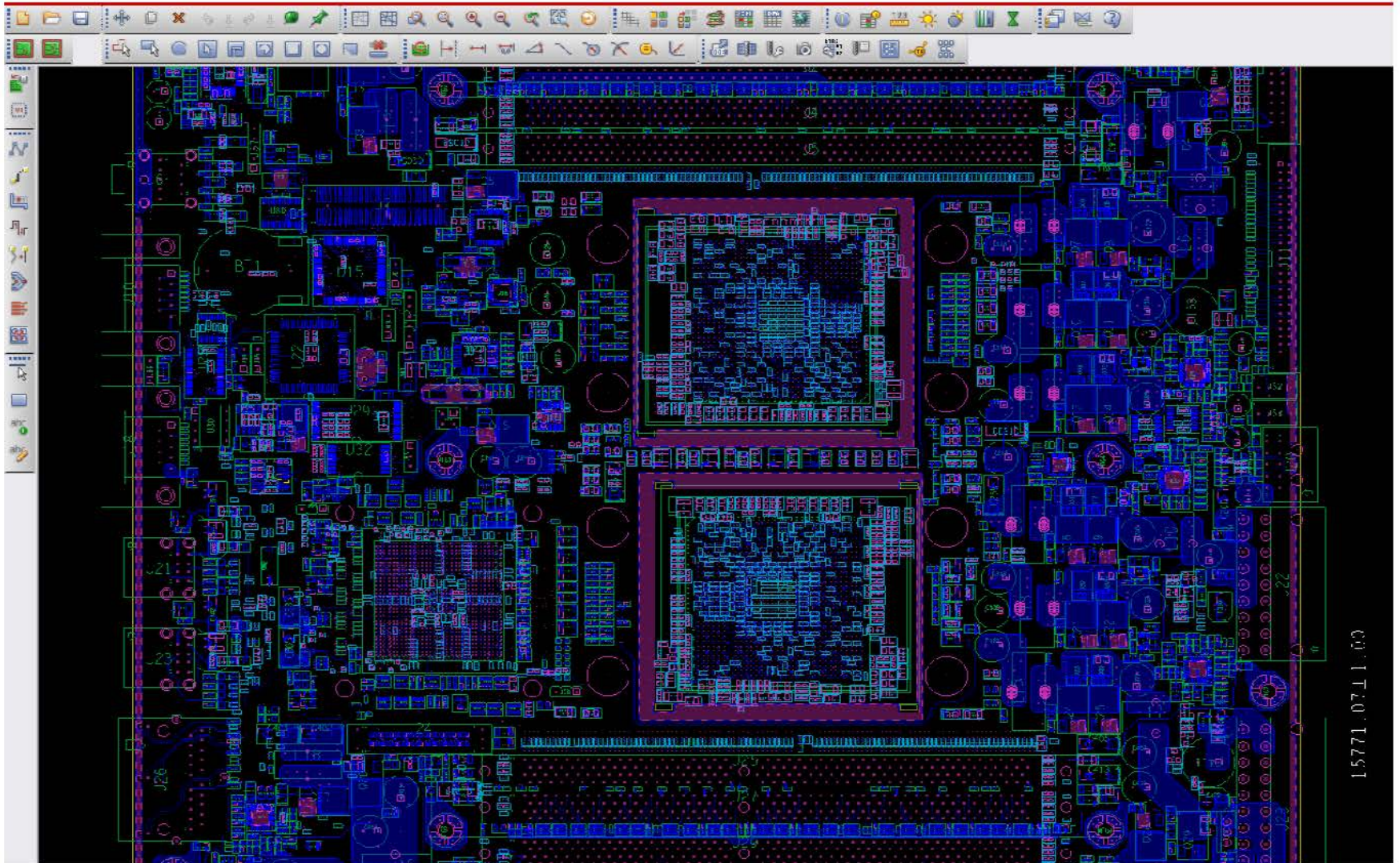

Heatsink Actually Grounded

Cavity Effect for Heatsink Grounding

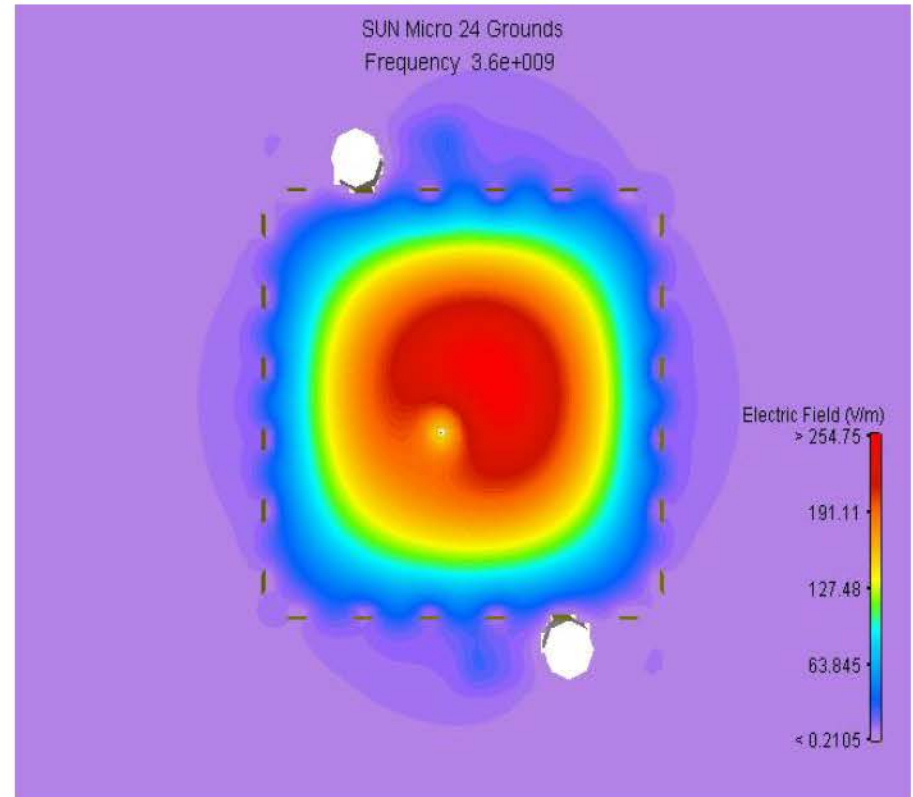
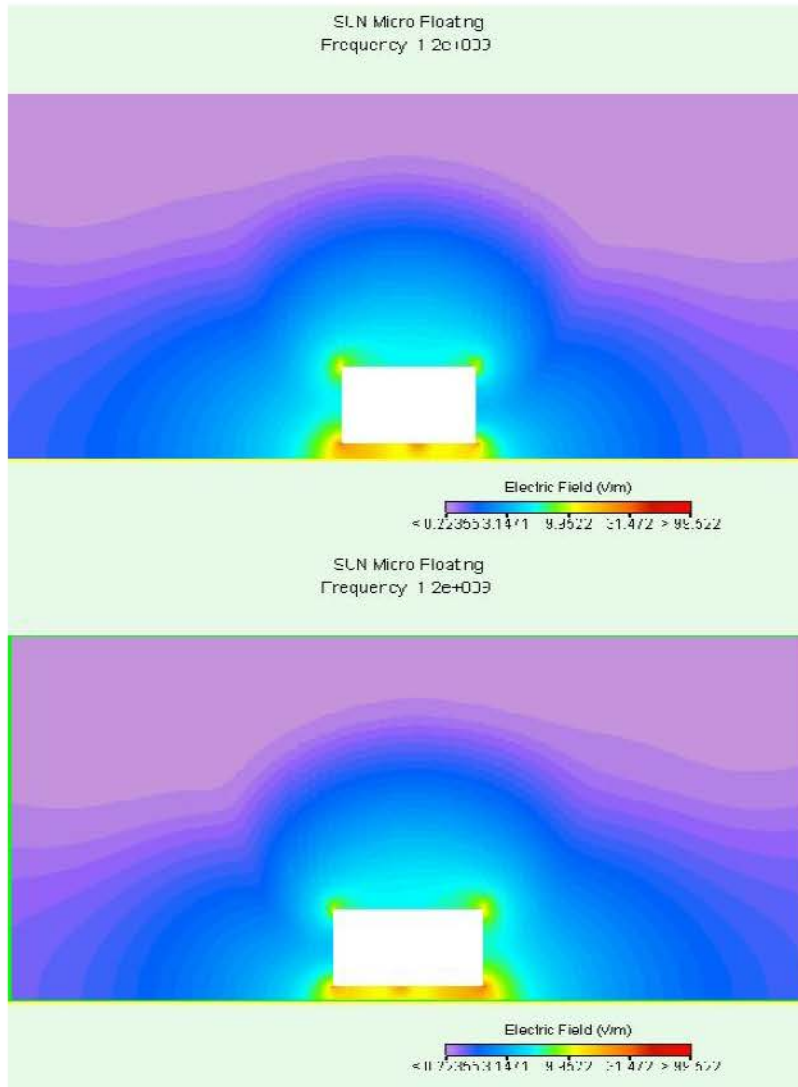

$$f_{(i,j,k)} = 150 \cdot \sqrt{\left(\frac{i}{L}\right)^2 + \left(\frac{j}{H}\right)^2 + \left(\frac{k}{W}\right)^2}$$

Source – Aperture Coupling

- The main two aspects we were looking for:

- The effect of chassis resonances

- The effect of direct coupling from a potential noise source to a potential antenna

- For each chassis resonance, the maximum energy is at the fundamental frequency of the resonance. For the higher modes the energy decreases with the order of the mode. From a practical point of view, this means that the most dangerous internal resonances will be below 1GHz, and to be on the safe side we may extend this to 3GHz. However, we expect that the energy in the very high modes, above 10GHz to be so small that the chassis resonance in itself will be not a problem above 10GHz (for normal sized 19" rack chassis).
- We may use 3GHz as upper limit for calculating the riveting (tux) pitch for the areas which are not in the path of a direct coupling to an internal source.
- For near-field direct coupling between an internal source and an aperture, the most important parameter is the source-aperture distance.
- For any significant internal source we need to have a distance to the closest aperture of at least 3-5 times the longest dimension of the aperture

Unified Multipoint Grounding

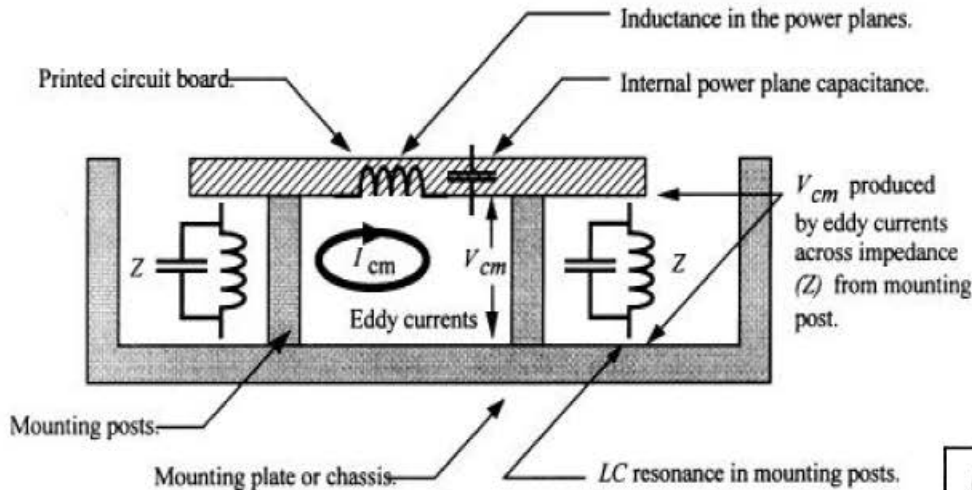

APPLICATION MODEL OF MULTIPOINT GROUNDING

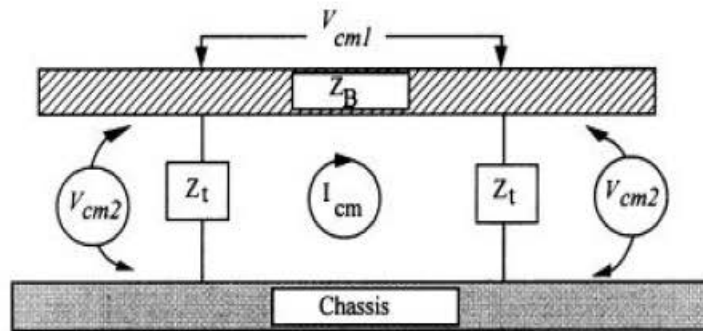

V_{cm2} is reduced by the mounting posts (ground stitch locations). Resonance is thus controlled, along with enhanced RF suppression.

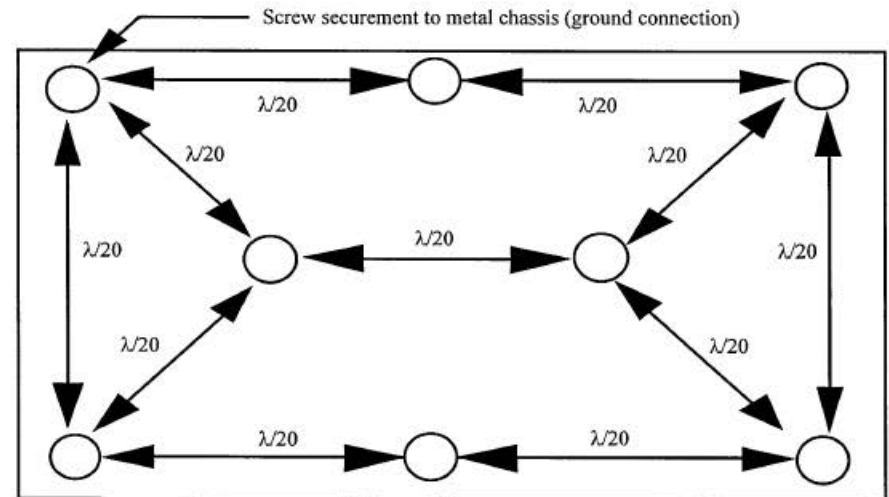

Distance between screws (chassis ground) in any axis (x- or y-axis) should not exceed $\lambda/20$ of the highest edge rate generated within the printed circuit board.

Old recommendations – impossible to use at the current frequencies

Shielding Effectiveness Evaluation

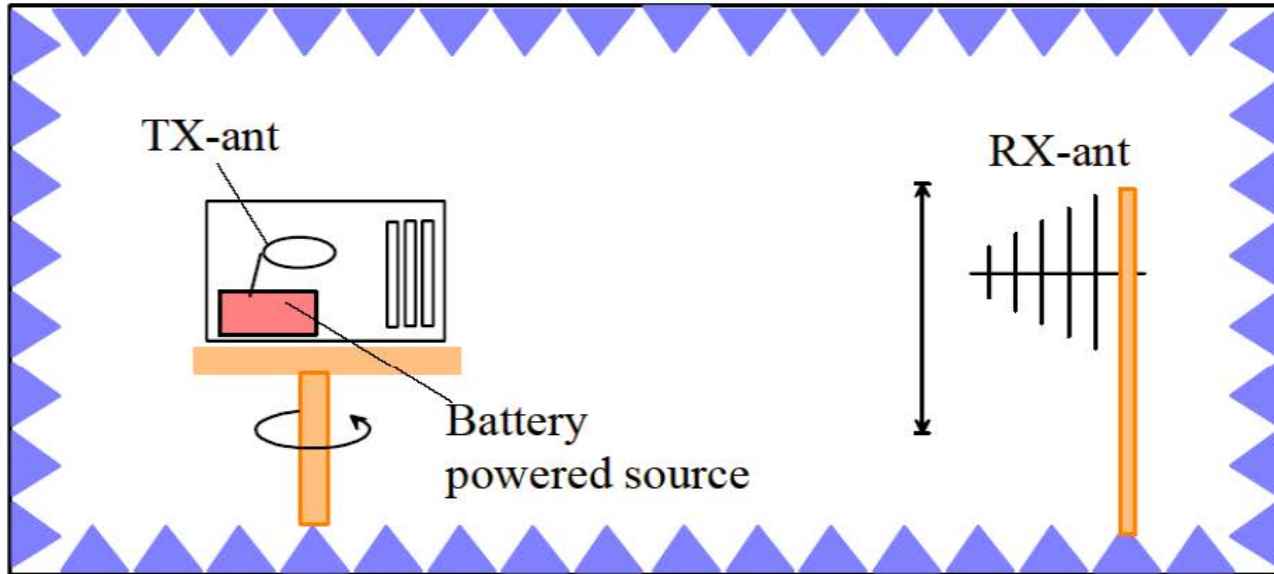

Battery powered source inside:

- + No change to the enclosure
- + easy setup in existing emissions measurement chambers
- No synchronization between receive and transmit frequencies (fill-in done)
- S/N may be limited

Shielding Effectiveness Evaluation – Small Monopole

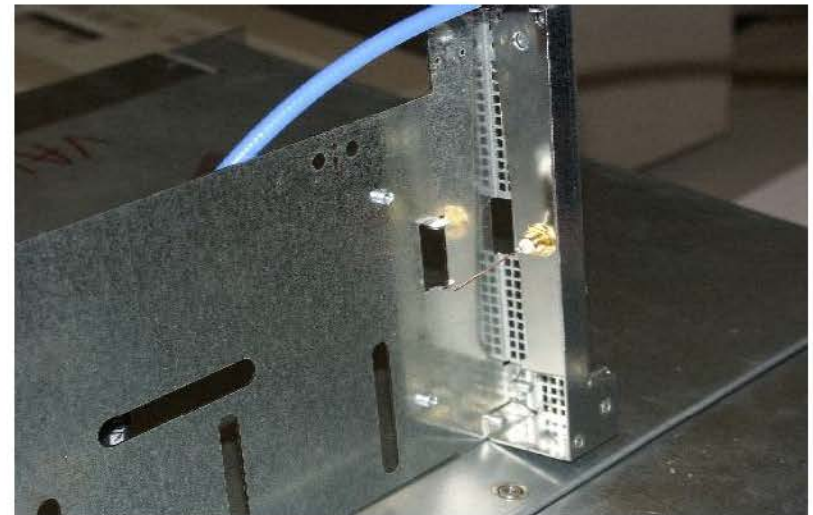

Shielding Effectiveness Evaluation – Small Monopole

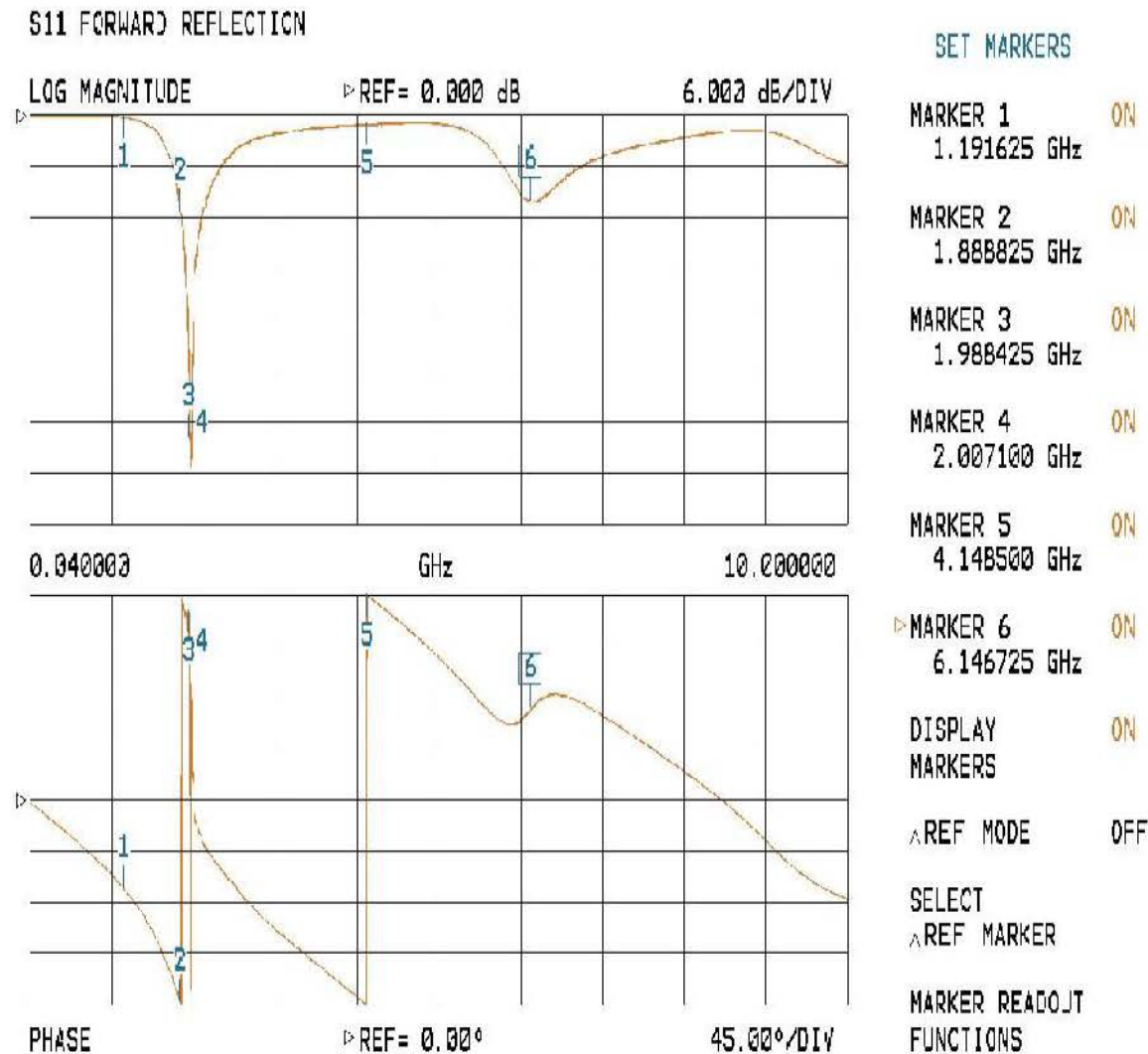

Calibration – small monopole only

Shielding Effectiveness Evaluation – Small Monopole

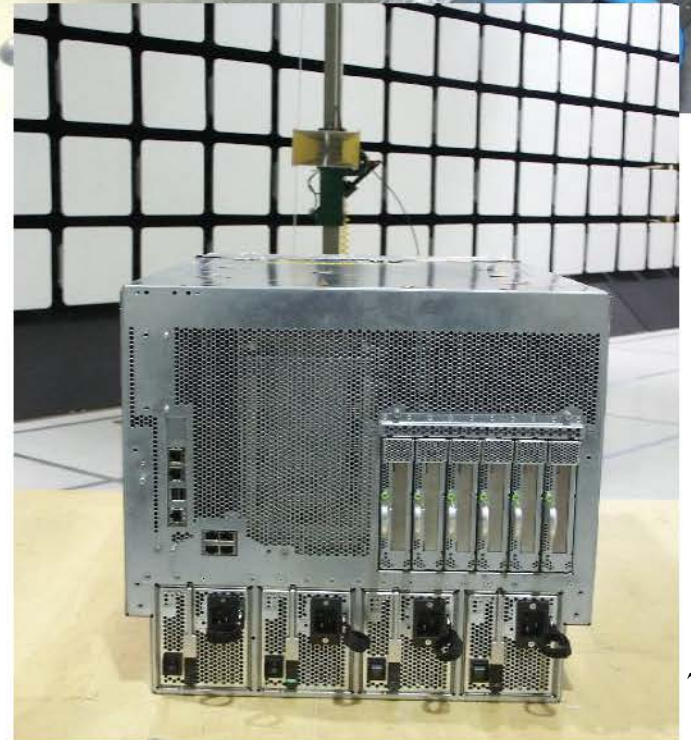
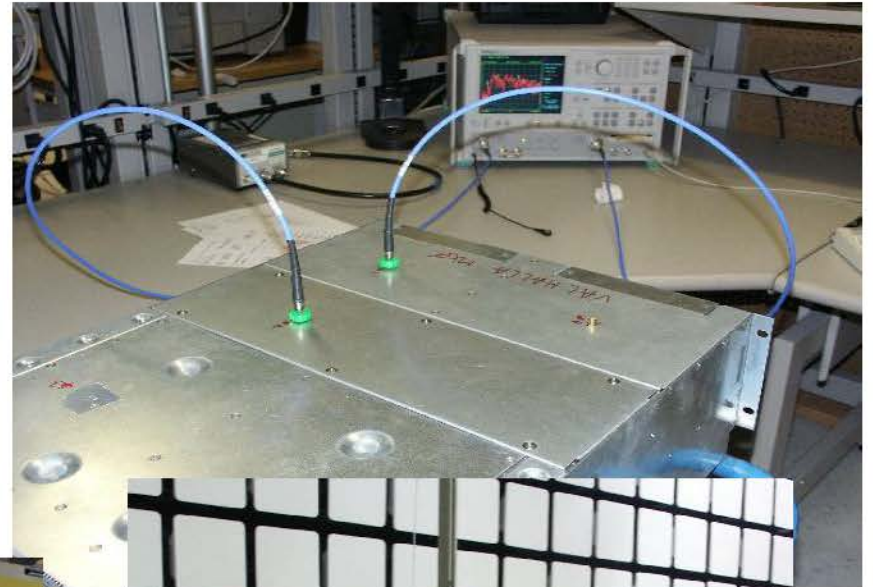

Shielding Effectiveness Evaluation – Comb Generator

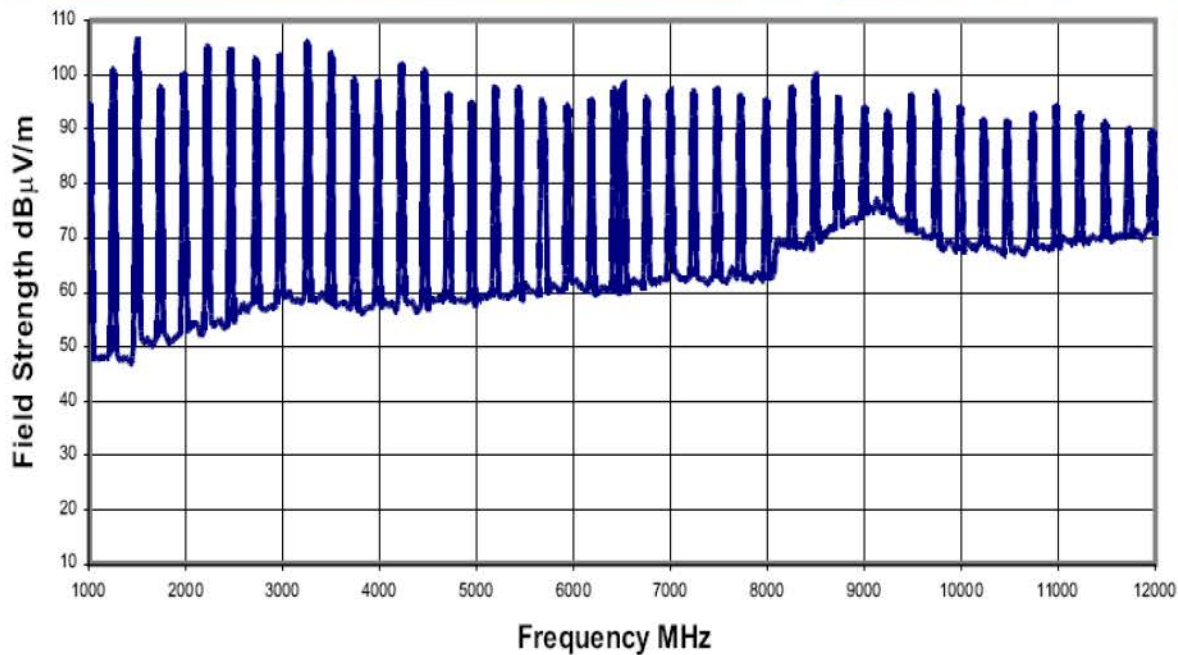
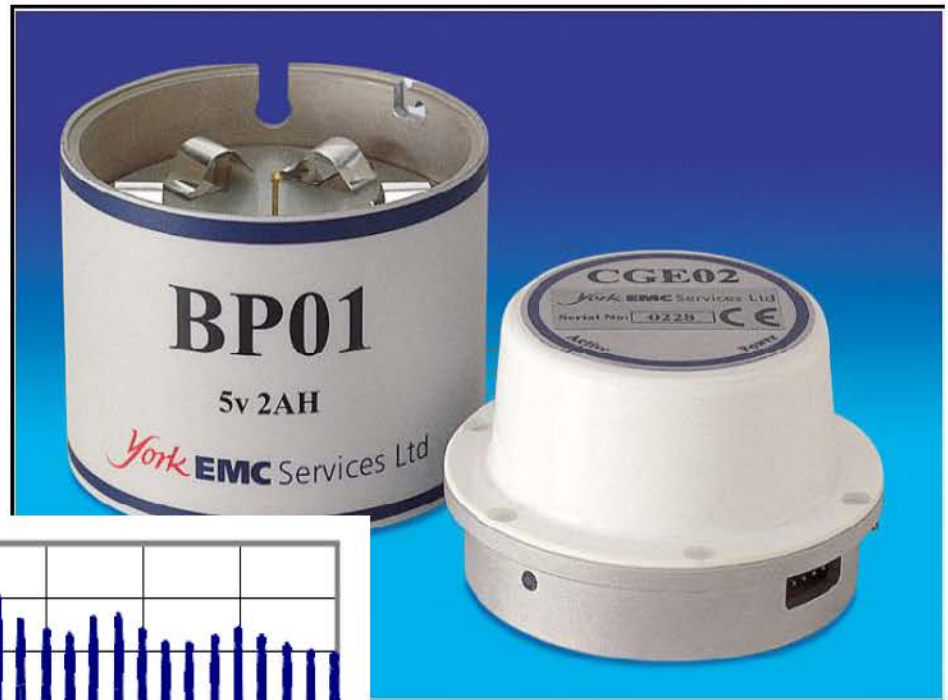

Shielding Effectiveness Evaluation – Comb Generator

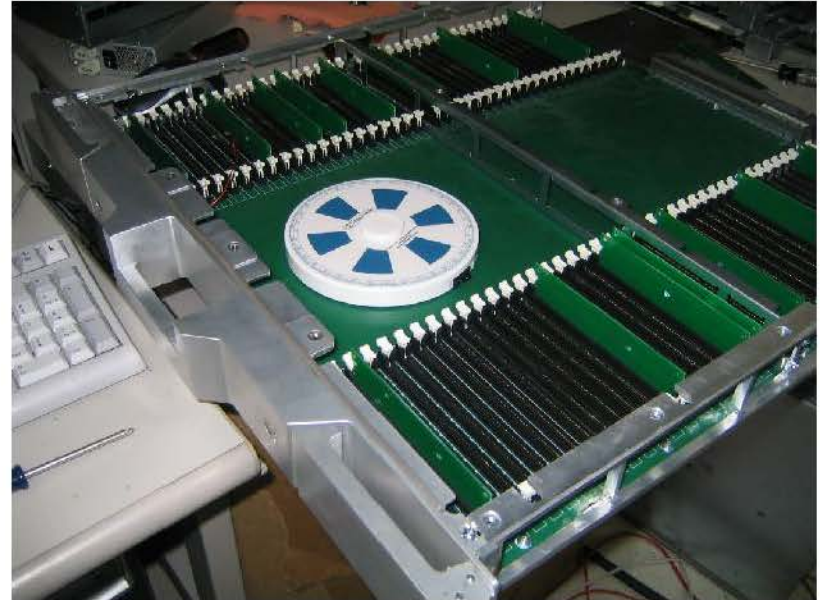

Shielding Effectiveness Evaluation – Comb Generator

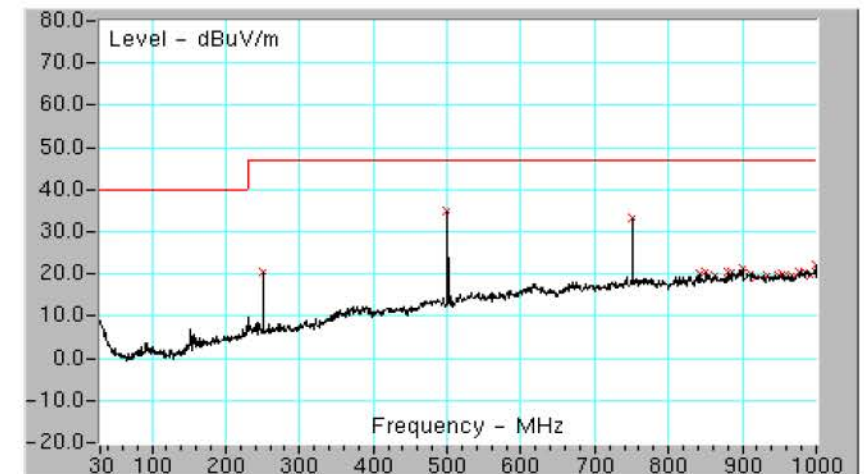
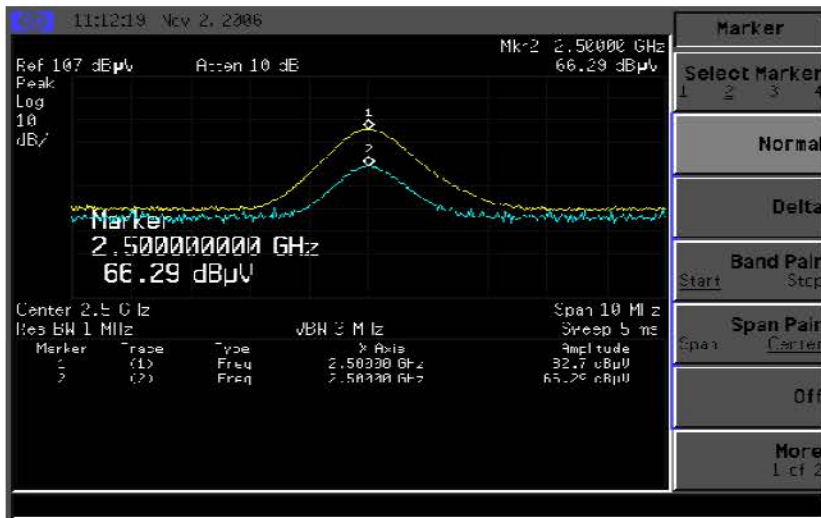
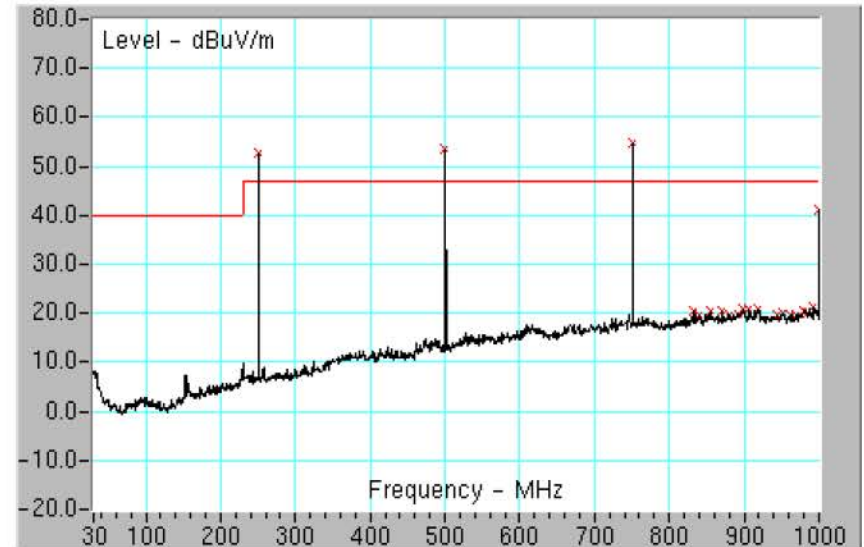
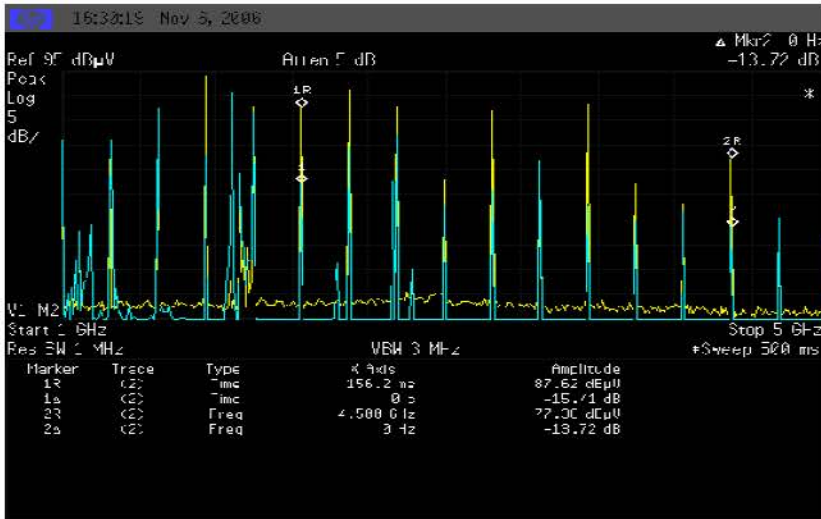

The effect of extra sealing the lid, CGE02 behind PCI_E, with and w/o .
 Typical A/B comparison to evaluate the effect of a gasket or aperture.

Shielding Effectiveness Evaluation – Comb Generator

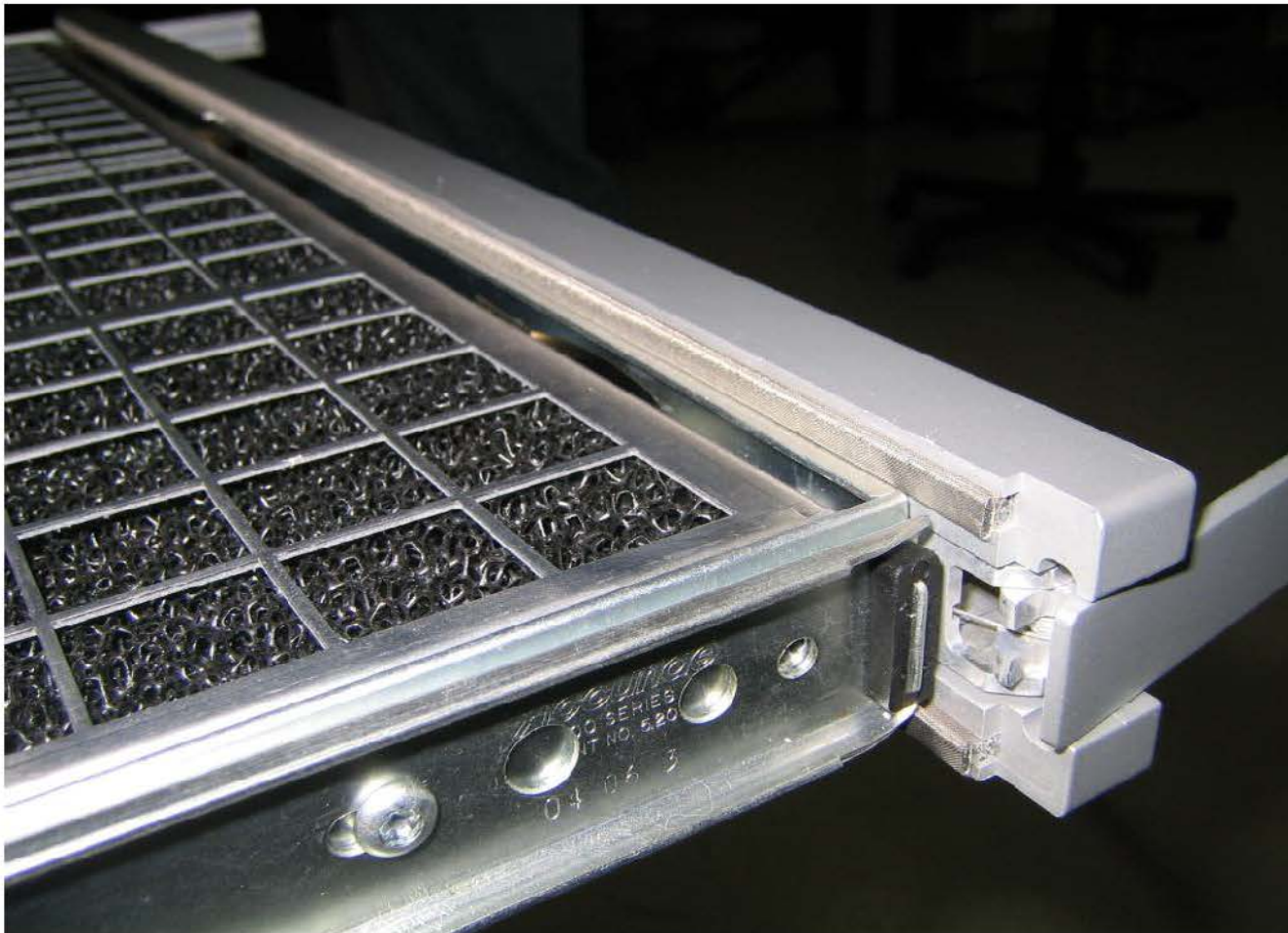

Air filter evaluation – use of conductive foam between air inlet
and CPU area

Shielding Effectiveness Evaluation – Stirred Mode Reverberation Chamber

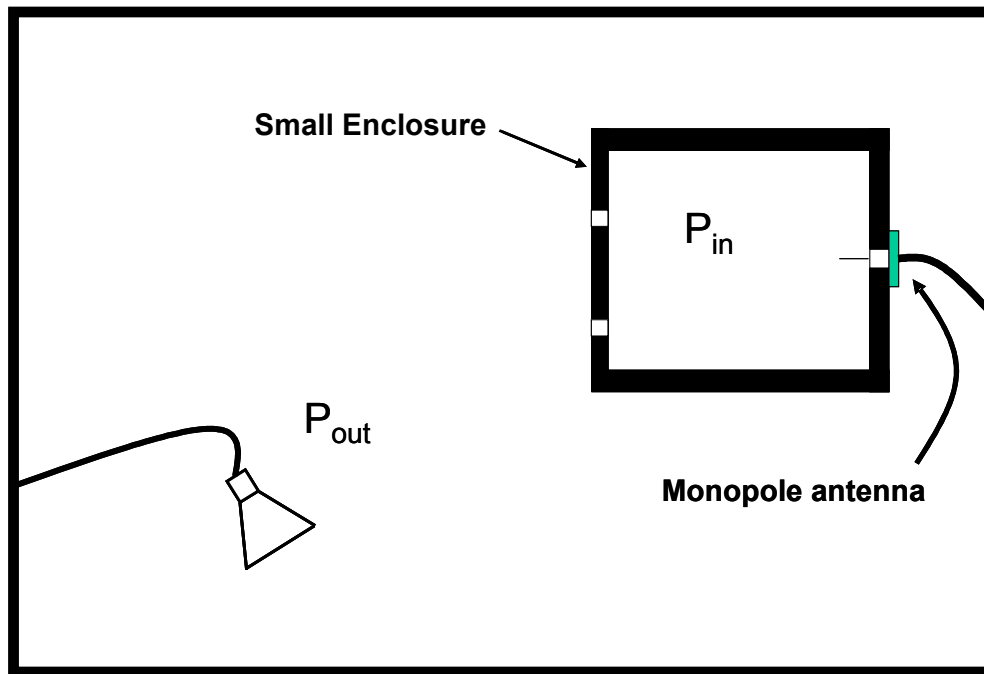

Local Shielding Using Thermoplastic Material

Best results with multilayer shield:
Steel (2 μ m)-Copper (4 μ m)-Steel (2 μ m)
PVC support: 25 mils

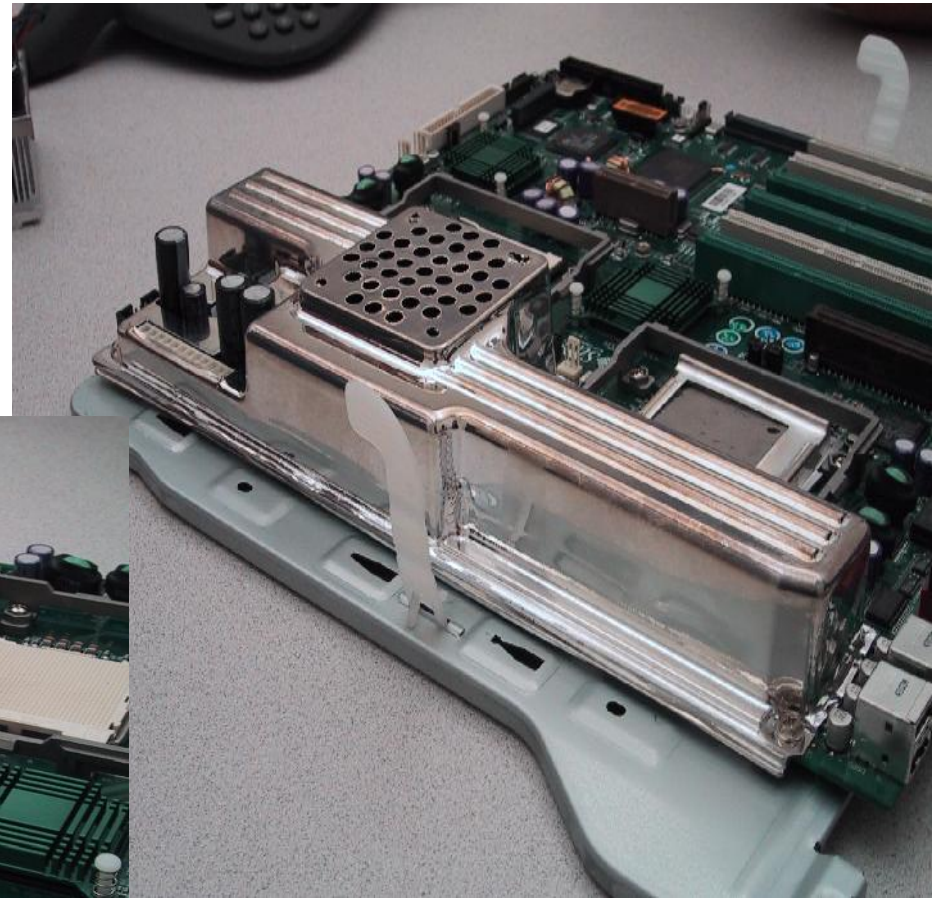
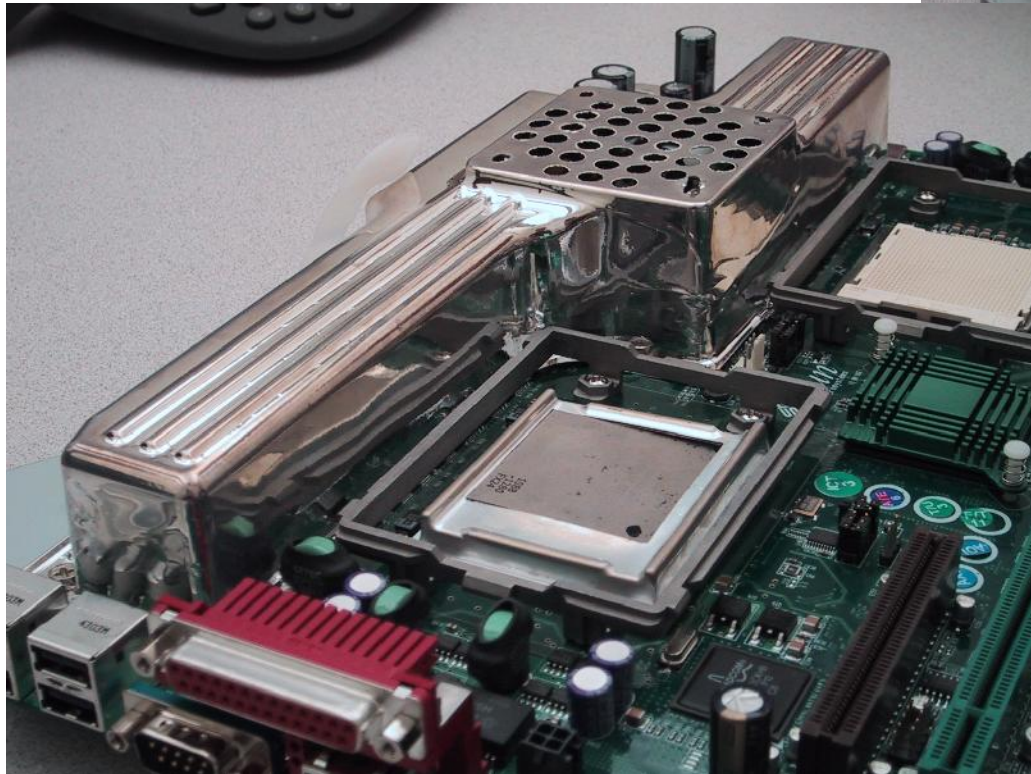

Memory harmonics <1GHz (x266MHz)
Grounding is critical

Local Shielding Using Thermoplastic Material

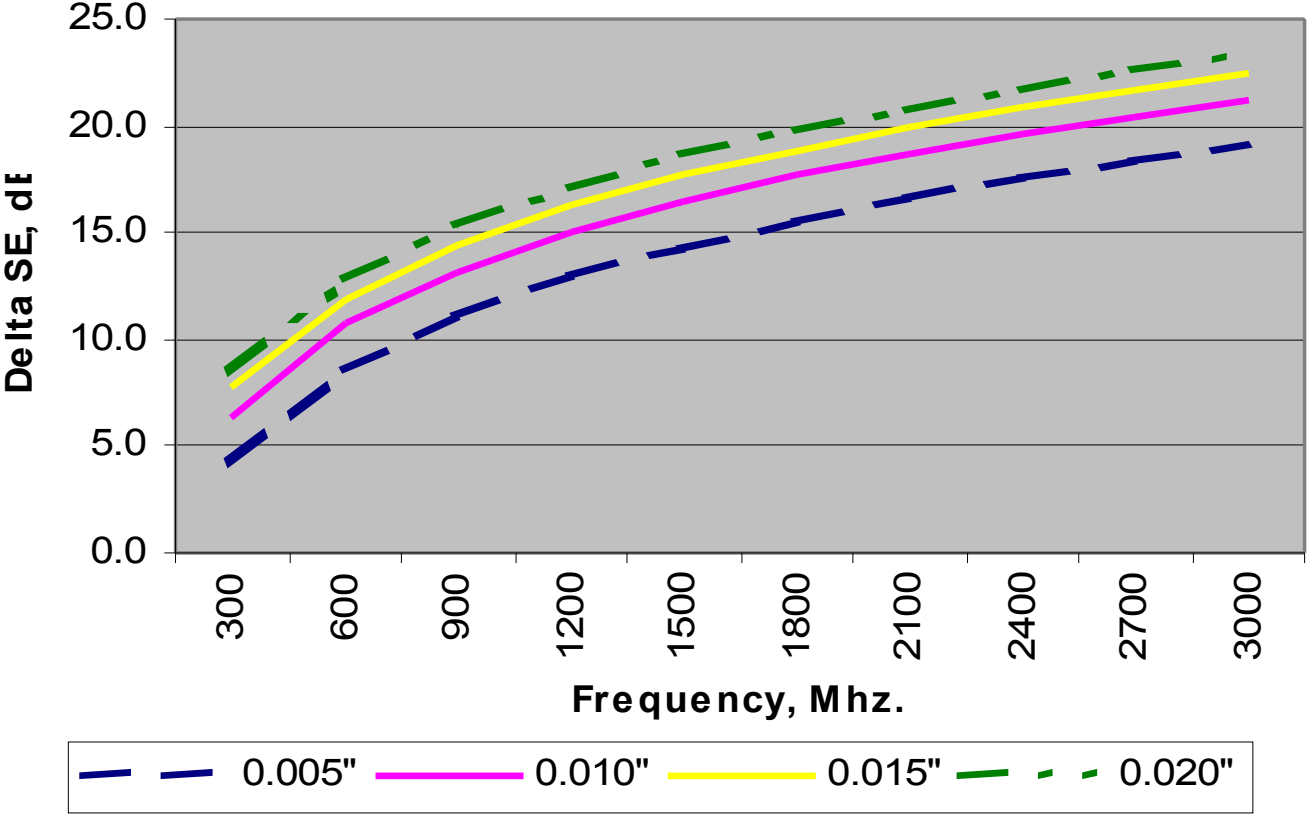

Effect of layer separation through the thickness of the thermoplastic base

Shield Coating and RoHS

- RoHS requires less than 0.1% Hexavalent Chromium present as an 'homogeneous material', not intentionally added.
- Forms of chromium that are RoHS compliant: pure chrome plating (shiny, metallic), trivalent chromium conversion coatings (“Clear” or “Clear blue bright”).
- “Safe” substitutions for hexavalent chromium conversion coatings for steel:
 - Use aluminized steel (T2-65 or T2-LC), not galvanized (electro-galvanized steel is linked to zinc whiskers, but also NEBS GR78 CORE compliance prohibits the use of ANY zinc in our systems, even as an alloying element over 15%)
 - If EMI is not an issue, phosphatizing and painting is also an option
 - If NEBS compliance not an issue, then use “Clear blue bright” trivalent chromium with acid bath electrolytic zinc underplate: “Zinc plate per ASTM B-633 SCI Type III with clear trivalent chromate conversion coating. Must withstand min. 96 hr ASTM B-166 Salt Spray. No additional dips or coatings.”

Coating

- Things to watch for with the trivalent chromium coating:
 - Some less-than-reputable coaters will try to get away with a hexavalent (or trivalent) chromium conversion coating to which they add a blue dye to make it look like the clear blue bright trivalent. In reality, the blue color comes from added cobalt to the trivalent coating bath, which also enhances the corrosion resistance. We may need to send samples for an external hex chrome "spot check" at a lab to be sure.
 - There should be no additional top coats over the clear blue bright trivalent chromium finish. Any additional top coat will most likely be organic and will interfere with the EMI attenuating properties. A surface resistivity check can likely determine the presence of a top coat.
- For aluminum:
 - Determine if a coating is really needed
 - If a coating is needed, preferred use is trivalent chromium coating
- NOTE: If EMI is not an issue, anodizing is also an option

Coating

- Chromate type conversion coatings have been observed to require around 20 psi to obtain low readings. Even then, in comparison to bright tin, the resistivity is high.
- Chromate on aluminum has been measured to be around 170 milliohms at 20 psi, while bright tin on aluminum has been observed to be less than 10 milliohms at only 8 psi. Very important above few GHz.
- There is data that shows the surface contact resistance to be several hundreds of milliohms and does not reduce down to below 30 milliohms until a pressure of around 200-250 psi for a nickel coating on aluminum (because of oxide).
- Use mechanical stops either stamped into or bends added to prevent exceeding the maximum compression value, typically 90-95% of the gasket height.

Coating

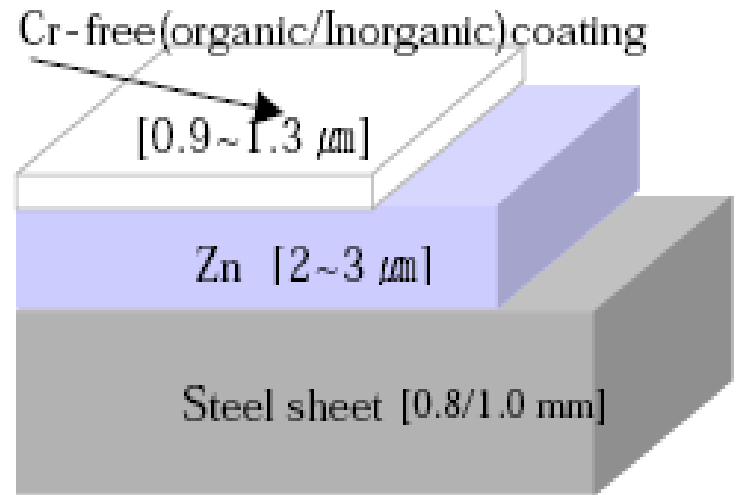
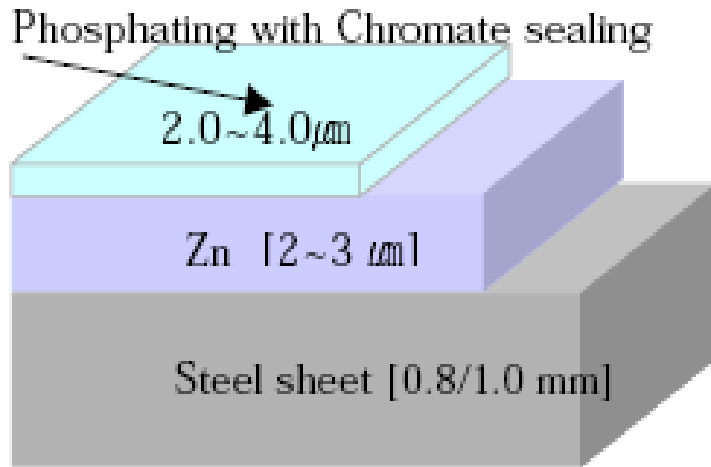

- The coating must pass multiple type of tests: Conductivity, Anti-Finger printing test, Adhesive tape testing without peel off, Good corrosion resistance, Stamp / Paintability Test(scratch and peel off), Humidity Test (60oC / 95%H / 192 hours) without Blister or Rust, Anti-Chemical Resistance.

Effect of Coating on Surface Resistivity (ASTM D257)

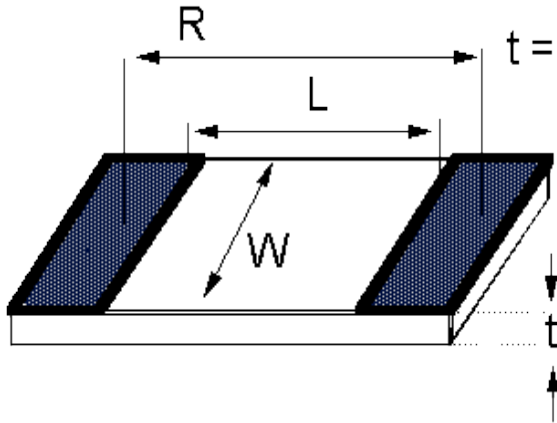

$$R = \rho_v \frac{1}{t} \frac{L}{W} = \rho_s \frac{L}{W}$$

$$\rho_s = R \quad \text{if } L=W \text{ (square)}$$

t = thickness of the test specimen

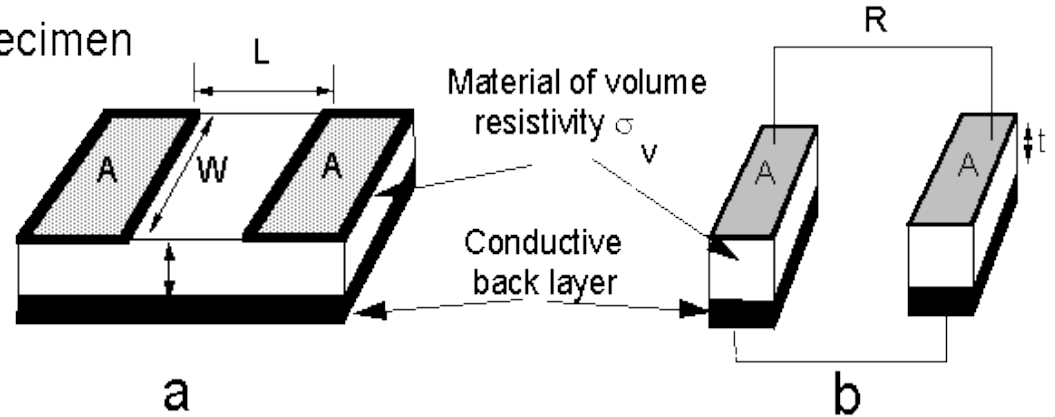

$$\rho_s = \text{surface resistivity } [\Omega / \text{square}]$$

$$R = \rho_v \cdot \frac{t}{A} \cdot 2$$

- For thin, homogeneous and volume conductive materials, the **apparent** surface resistivity is equal to the **true** volume resistivity divided by the thickness.
- If the coating is more resistive than the base metal, and L is much greater than t, the circuit can be approximately shown as in Fig. b. It is actually volume resistivity which is being measured and surface resistivity, in fact a nonexistent material property, acquires its apparent value depending on volume resistivity of the coating and specimen geometry (two serial resistors, connected by the conductive substrate). For a more conductive coating σ_s makes sense.
- Look for 100 mohms/square or less

Plastic Coating – An Example



- A performance increase of 10 dB can be observed on critical frequencies.
- Vapor deposition is the most environmentally sound process for high quality conductive coatings. Aluminum is not considered a hazardous material and is thus completely compliant with the EU RoHS Directive. The coating is approximately 0.5 μm to 3 μm thick.
- European Union (EU) Waste Electrical and Electronic Equipment Directive (WEEE)

Shielding and Corrosion

- Corrosion is also a concern because it leads to reduced shielding effectiveness due to causing the gasket material to become an insulator or creating new problem frequencies through nonlinear mixing.
- There are two types of corrosion: galvanic (most common) and electrolytic.

Galvanic corrosion is due to contact between two dissimilar metals in the presence of moisture. The potential developed depends upon their relative position in the electrochemical or galvanic series.

- Electrolytic corrosion is due to current flow between two metals in the presence of an electrolyte (which could be just slightly acidic ambient moisture). The major contributors to this problem are surface contact area, material dissimilarity and the presence of an electromotive, usually moisture.

- Galvanically compatible materials are those that are within 0.25 volts of each other. For commercial applications where the environment is controlled, the range can be increased up to 0.5 to 0.6 volts. If large contact voltages occur, the more anodic material will eventually be destroyed. To prevent this problem, either the gasket material or mating surface, or both, will need to be plated with a material or finish that is compatible with the base material. The closer the materials that are in contact with each other are in the galvanic series, then the lower the probability of corrosion. A typical galvanic activity table:

Cathodic: Gold (+1.5V), Silver (0.8V), Copper (0.34V), Hydrogen (0V), Tin (-0.137), Nickel (-0.257), Iron (-0.44), Zinc (-0.76V), Aluminum (-1.66V), Magnesium (-2.37) **Anodic**

Shielding and Safety Aspects

- Steel ball impact (important for plastic honeycomb)
- Finger test (important for hole size)
- Hazardous voltage (chassis interlock)
- Flammability (type of plastic materials, fire enclosure, mesh)
- UL recognized coating (acceptable if the conductive coating is “adequately” bonded to the substrate material).

Thanks !

Sergiu Radu

EMC Design Engineering

Sun Microsystems, Inc.

(650) 786 3465

sergiu.radu@sun.com